

To: Prospective Bidders

From:
WBRC Inc.
44 Central Street
Bangor, ME 04401-5116
(207) 947-4511
www.wbrcinc.com

This Addendum forms a part of the Contract Documents and modifies the original Bidding Documents dated January 21, 2022, as noted below. Acknowledge receipt of the Addendum in the space provided on the Bid Form. Failure to do so may subject the Bidder to disqualification.

This Addendum consists of the following:

- Clarifications
- Document Changes
- Specification Changes
- Drawing Changes

CLARIFICATIONS:

1. Pre-Bid Attendance Sheet attached.
2. Q: UMPI webpage states any visitors must be vaccinated or show proof of negative test within 72 hours. Is this the same for contractors on the project?
A: The short answer is no, contractors are not required to be vaccinated.
"Visitors, including contractors to the University, also are expected to follow CDC guidance generally or their own specific safety plan if applicable and in place with the University. This means visitors should not come to campus if they are currently subject to quarantine or isolation per CDC guidelines (External Site)."
"The University of Maine System does require evidence of vaccination status or a negative test for entrance to indoor group gatherings of more than 250 persons."
3. Q: If lead paint is present is the owner setting up abatement to start on March 7th?
A: The Owner is coordinating testing to begin prior to March 7th.
4. Q: Please confirm the University's policy on mask coverings and vaccines.
A: Mask coverings are never required outside. Masks are required inside if the building is not closed to others. If the building is closed to others than the contractor's site specific safety plan takes effect.
<https://www.maine.edu/together/community-guidance/everyone/>
5. Q: Will electricity be provided and if so – how many volts/amps? Is it 3 phase?
A: 120/208V, 3 phase.
6. Q: Do you know the exact thickness of the concrete in the gym?
A: Per the original drawings, the slab was designed as a 4" slab

DOCUMENT CHANGES:

7. Document 00 73 46, Wage Rates, DELETE 2021 Wage Rates and REPLACE with attached 2022 Wage Rates.

SPECIFICATION CHANGES:

8. Section 01 10 00, Summary, DELETE section and REPLACE with attached section.
9. Section 05 50 00, Metal Fabrications, DELETE section and REPLACE with attached section.
10. Section 07 53 23, Ethylene-Propylene-Diene-Monomer (EPDM) Roofing, DELETE section and REPLACE with attached section.
11. Section 07 54 19, Polyvinyl-Chloride (PVC) Roofing, DELETE section and REPLACE with attached section.

12. Section 09 64 66, Wood Athletic Flooring, DELETE section and REPLACE with attached section.
13. Section 09 68 13, Tile Carpeting, ADD Section
14. Section 09 91 20, Painting, DELETE section and REPLACE with attached section.
15. Section 23 51 13.16 Vent Dampers, ADD Section
16. Section 23 51 33, Insulated Sectional Chimney, ADD Section.
17. Section 23 52 23, Cast-Iron Boilers, ADD Section
18. Section 26 55 68, Athletic Sports Lighting, ADD Section.

DRAWING CHANGES:

19. Sheet S102, Roof Plan, DELETE Sheet and REPLACE with attached sheet.
20. Sheet AD101, First Floor Removals Plan, DELETE Sheet and REPLACE with attached sheet.
21. Sheet AE101, First Floor Plan, DELETE Sheet and REPLACE with attached sheet.
22. Sheet AE103, Roof Plan, DELETE Sheet and REPLACE with attached sheet.
23. Sheet AE104, Reflected Ceiling Plan, DELETE Sheet and REPLACE with attached sheet.
24. Sheet AE201, Building Elevations, DELETE Sheet and REPLACE with attached sheet.
25. Sheet AE202, Building Elevations, DELETE Sheet and REPLACE with attached sheet.
26. Sheet AE501, Exterior Details, DELETE Sheet and REPLACE with attached sheet.
27. Sheet AE601, Details, Schedule and Interior Elevations, DELETE Sheet and REPLACE with attached sheet.
28. Sheet AF101, Finish Floor Plan, Sheet AE201, Building Elevations, DELETE Sheet and REPLACE with attached sheet.
29. Sheet MD101, First Floor Mechanical Removal Plan, DELETE Sheet and REPLACE with attached sheet.
30. Sheet M-101, First Floor Mechanical Plan, DELETE Sheet and REPLACE with attached sheet.
31. Sheet E-101, First Floor Electrical Plan, DELETE Sheet and REPLACE with attached sheet. Lighting control panel removed.
32. Sheet E-501, Electrical Details, DELETE Sheet and REPLACE with attached sheet. Lighting control schedule removed.
33. Sheet E-601, Panelboard Schedules, DELETE Sheet and REPLACE with attached sheet. Panel Schedule P1 updated. Power to lighting control panel removed.

END OF ADDENDUM 01

Wieden Signin

| Name | Company | Email |
|---------------------|-------------------------------|----------------------------------|
| Nolan St | PATRICK ST. PETERS | psps@smcinc.me.com |
| Ron Flewelling | Sullivan & Merritt | r.flewelling@smcinc.net |
| Dean Staples | Staples Construction | dstaples1@maine.me.com |
| Tom Umel | Nickerson + O'Day | tumel@nickoday.com |
| Ryan Parker | Sprinkler Systems Inc | Ryan Parker 123456@gmail.com |
| Andrew Michaud | A.M. Construction | mpmichaud93@gmail.com |
| Paul Powers | Powers Roofing | paul@powersroofing.com |
| Jordan Powers | Powers Roofing | jordan@powersroofing.com |
| Joseph Allen | The Allen Company | joseph@niccait.com |
| Rick Noakes | A+L Construction | ank@ainop.com |
| Scott S. Sorellet | ARM Mechanical, Inc | sorellet@armmechanical.com |
| Josh Ouellette | Sullivan's Floor | sullivan's floor maine.me.com |

State of Maine
 Department of Labor
 Bureau of Labor Standards
 Augusta, Maine 04333-0045
 Telephone (207) 623-7906

Wage Determination - In accordance with 26 MRS §1301 et. seq., this is a determination by the Bureau of Labor Standards, of the fair minimum wage rate to be paid to laborers and workers employed on the below titled project.

**2022 Fair Minimum Wage Rates
 Building 2 Aroostook County
 (other than 1 or 2 family homes)**

| Occupational Title | Minimum Wage | Minimum Benefit | Total |
|--|--------------|-----------------|---------|
| Brickmasons And Blockmasons | \$35.00 | \$0.00 | \$35.00 |
| Carpenter | \$26.40 | \$12.38 | \$38.78 |
| Carpet Installers | \$20.50 | \$0.72 | \$21.22 |
| Cement Masons And Concrete Finisher | \$20.00 | \$4.44 | \$24.44 |
| Construction And Maintenance Painters | \$16.05 | \$0.40 | \$16.45 |
| Construction Laborer | \$18.00 | \$1.38 | \$19.38 |
| Control And Valve Installers And Repairers - Except Mechanical Door | \$26.00 | \$5.49 | \$31.49 |
| Crane And Tower Operators | \$25.75 | \$6.29 | \$32.04 |
| Drywall And Ceiling Tile Installers | \$25.49 | \$0.00 | \$25.49 |
| Earth Drillers - Except Oil And Gas | \$23.25 | \$5.53 | \$28.78 |
| Electricians | \$30.68 | \$6.37 | \$37.05 |
| Elevator Installers And Repairers | \$56.69 | \$42.31 | \$99.00 |
| Excavating And Loading Machine And Dragline Operators | \$25.25 | \$0.00 | \$25.25 |
| Fence Erectors | \$23.00 | \$5.43 | \$28.43 |
| Floor Layers - Except Carpet/Wood/Hard Tiles | \$22.00 | \$5.25 | \$27.25 |
| Glaziers | \$26.00 | \$1.90 | \$27.90 |
| Hazardous Materials Removal Workers | \$20.38 | \$2.17 | \$22.55 |
| Heating And Air Conditioning And Refrigeration Mechanics And Installers | \$28.00 | \$4.26 | \$32.26 |
| Heavy And Tractor - Trailer Truck Drivers | \$20.75 | \$0.20 | \$20.95 |
| Industrial Machinery Mechanics | \$26.00 | \$5.82 | \$31.82 |
| Industrial Truck And Tractor Operators | \$24.00 | \$5.61 | \$29.61 |
| Insulation Workers - Floor Ceiling And Wall | \$26.25 | \$1.43 | \$27.68 |
| Ironworker - Ornamental | \$25.00 | \$3.32 | \$28.32 |
| Light Truck Or Delivery Services Drivers | \$20.00 | \$2.30 | \$22.30 |
| Mobile Heavy Equipment Mechanics - Except Engines | \$24.88 | \$4.09 | \$28.97 |
| Operating Engineers And Other Equipment Operators | \$26.00 | \$2.15 | \$28.15 |
| Paving Surfacing And Tamping Equipment Operators | \$33.12 | \$0.00 | \$33.12 |
| Pipelayers | \$28.00 | \$7.20 | \$35.20 |
| Plumbers Pipe Fitters And Steamfitters | \$26.00 | \$4.15 | \$30.15 |
| Reinforcing Iron And Rebar Workers | \$21.00 | \$5.69 | \$26.69 |
| Roofers | \$20.00 | \$0.46 | \$20.46 |
| Sheet Metal Workers | \$22.75 | \$6.88 | \$29.63 |
| Sider | \$18.00 | \$2.44 | \$20.44 |
| Structural Iron And Steel Workers | \$23.88 | \$4.51 | \$28.39 |
| Tapers | \$25.00 | \$1.13 | \$26.13 |
| Telecommunications Equipment Installers And Repairers - Except Line Installers | \$33.25 | \$10.78 | \$44.03 |
| Tile And Marble Setters | \$25.50 | \$5.30 | \$30.80 |

Welders are classified as the trade to which welding is incidental (e.g. welding structural steel is Structural Iron and Steel Worker)

Apprentices – The minimum wage rate for registered apprentices are those set forth in the standards and policies of the Maine State Apprenticeship and Training Council for approved apprenticeship programs.

For any other specific trade on this project not listed above, contact the Bureau of Labor Standards for further clarification.

Title 26 §1310 requires that a clearly legible statement of all fair minimum wage and benefits rates to be paid the several classes of laborers, workers and mechanics employed on the construction on the public work must be kept posted in a prominent and easily accessible place at the site by each contractor and subcontractor subject to sections 1304 to 1313.

Appeal – Any person affected by the determination of these rates may appeal to the Commissioner of Labor by filing a written notice with the Commissioner stating the specific grounds of the objection within ten (10) days from the filing of these rates.

A true copy

Attest: 
 Scott R. Cotnoir
 Wage & Hour Director
 Bureau of Labor Standards

Expiration Date: 12-31-2022

SECTION 01 10 00
SUMMARY

PART 1 - GENERAL

1.1 RELATED DOCUMENTS

- A. Drawings and general provisions of the Contract, including General and Supplementary Conditions and other Division 01 Specification Sections, apply to this Section.

1.2 SUMMARY

A. Section Includes:

- 1. Project information.
- 2. Work covered by Contract Documents.
- 3. Work performed by Owner.
- 4. Owner-furnished/Owner-installed (OFOI) products.
- 5. Contractor's use of site and premises.
- 6. Coordination with occupants.
- 7. Work restrictions.
- 8. Specification and Drawing conventions.
- 9. Miscellaneous provisions.

B. Related Requirements:

- 1. Section 01 50 00 "Temporary Facilities and Controls" for limitations and procedures governing temporary use of Owner's facilities.
- 2. Section 01 73 00 "Execution" for coordination of Owner-installed products.

1.3 DEFINITIONS

- A. Work Package: A group of specifications, drawings, and schedules prepared by the design team to describe a portion of the Project Work for pricing, permitting, and construction.

1.4 PROJECT INFORMATION

A. Project Identification: UMPI - WIEDEN HALL RENOVATION

- 1. Project Location: University of Maine at Presque Isle, 181 Main Street, Presque Isle, ME 04769

B. Owner: University of Maine at Presque Isle

- 1. Owner's Representative: Jacob Olsen, Project Manager, 5765 Service Building 106, Rm 108, Orono, ME 04469.
 - a. Phone Number: (207) 581-2700
 - b. Email Address: jacob.olsen@maine.edu

C. Architect: WBRC Inc.

1. Architect's Representative: Kristian Kowal, AIA, NCARB and Adam Gillespie, P.E.
 - a. Phone Number: (207) 947-4511
 - b. Email Address: kristian.kowal@wbrcae.com and adam.gillespie@wbrcae.com

D. Web-Based Project Software: Project software will be used for purposes of managing communication and documents during the construction stage.

1. See Section 01 31 00 "Project Management and Coordination." for requirements for using web-based Project software.

1.5 WORK COVERED BY CONTRACT DOCUMENTS

A. The Work of Project is defined by the Contract Documents and includes, but is not limited to, the following:

1. Roof system, structural support and reinforcement, snow melt system at roof, exterior siding, mechanical units, sports lighting, catwalk systems, minor sitework associated with new mechanical pad and alternate cooling system, gym equipment, electric telescoping stands, sports flooring, acoustic ceilings, rerouted mechanical, electrical, sprinkler and other utilities, doors, glazing, louvers, foundation work, acoustic panels, electrical upgrades, masonry, interior finishes and other Work indicated in the Contract Documents.

B. Type of Contract:

1. Project will be constructed under a single prime contract.

1.6 WORK PERFORMED BY OWNER

A. Cooperate fully with Owner, so work may be carried out smoothly, without interfering with or delaying Work under this Contract or work by Owner. Coordinate the Work of this Contract with work performed by Owner.

B. Preceding and Concurrent Work: Owner will perform the following construction operations at Project site. Those operations are scheduled to be substantially complete before Work under this Contract begins.

1. Abatement related to the current project scope. The Owner will endeavor to remove hazardous materials prior to construction however some portions of the work require the Contractor to coordinate its work with the Owner so that abatement, such as in the boiler room happens concurrently with construction demolition.
 - a. Note that the boiler will need to remain online until the close of the heating system (May 15) before it is demolished.
 - b. See Appendix A at the end of this section for a detailed plan of the anticipated Owner abatement areas and their anticipated dates for completion.

1.7 OWNER-FURNISHED/OWNER-INSTALLED (OFOI) PRODUCTS

A. The Owner will furnish and install products indicated.

B. Owner-Furnished/Owner-Installed (OFOI) Products:

1. See notations in Contract Documents.

1.8 CONTRACTOR'S USE OF SITE AND PREMISES

- A. Unrestricted Use of Site with Exceptions: Contractor shall have full use of Project building for construction operations during construction period. See GI003 for laydown and fencing areas related to the project site. Extra care and caution should be exhibited while school is in session with safety of students and staff being paramount.
1. Fenced areas towards the north of the building shall remain open until needed as a campus path runs through it.
 2. Athletic Training Wing: Owner requires use of the Athletic Training wing west of 10 line on WBRC's plans. This area will be occupied until May 15, 2022 and will need to be reoccupied on August 8, 2022. Coordinate with Owner.
 3. Batting Cage: The Owner requires the use of the second floor batting cage south of B line on the second floor until March 12, 2022.
 4. Should the Owner require further access, it will coordinate with the Contractor to minimize disruptions.
 5. **New Boiler: The new boiler system, indicated in these documents, must be operational by August 29th.**
 6. Final Completion must be achieved by December 29, 2022 as the Owner will begin use of the premises for its sports seasons.
- B. Condition of Existing Building: Maintain portions of existing building affected by construction operations, whether in the project scope or not, in an "as-is" and weathertight condition throughout construction period. Repair damage caused by construction operations. Contractor to submit photos to the Owner of the affected areas prior to beginning construction.
- C. Condition of Existing Grounds: Maintain portions of existing grounds, landscaping, and hardscaping affected by construction operations throughout construction period. Repair damage caused by construction operations. Contractor to submit photos to the Owner of the affected areas prior to beginning construction.

1.9 COORDINATION WITH OCCUPANTS

- A. Partial Owner Occupancy: Owner will occupy the premises during the construction period as stated in paragraph 1.8.A., with the exception of areas under construction. Cooperate with Owner during construction operations to minimize conflicts and facilitate Owner usage. Perform the Work so as not to interfere with Owner's operations. Maintain existing exits unless otherwise indicated.
1. Maintain access to existing walkways, corridors, and other adjacent occupied or used facilities. Do not close or obstruct walkways, corridors, or other occupied or used facilities without written permission from Owner and authorities having jurisdiction.
 2. Provide not less than 72 hours' notice to Owner of activities that will affect Owner's operations.
- B. Owner Limited Occupancy of Completed Areas of Construction: Owner reserves the right to occupy and to place and install equipment in completed portions of the Work, prior to Substantial Completion of the Work, provided such occupancy does not interfere with completion of the Work. Such placement of equipment and limited occupancy shall not constitute acceptance of the total Work.
1. Architect will prepare a Certificate of Substantial Completion for each specific portion of the Work to be occupied prior to Owner acceptance of the completed Work.
 2. Obtain a Certificate of Occupancy from authorities having jurisdiction before limited Owner occupancy.
 3. Before limited Owner occupancy, mechanical and electrical systems shall be fully operational, and required tests and inspections shall be successfully completed. On occupancy, Owner will operate and maintain mechanical and electrical systems serving occupied portions of Work.
 4. On occupancy, Owner will assume responsibility for maintenance and custodial service for occupied portions of Work.

1.10 WORK RESTRICTIONS

- A. Comply with restrictions on construction operations.
 - 1. Comply with limitations on use of public streets, work on public streets, rights of way, and other requirements of authorities having jurisdiction.
- B. On-Site Work Hours: Limit work to between 7 a.m. to 5 p.m., Monday through Friday, unless otherwise coordinated with Owner. Work hours may be modified to meet Project requirements if approved by Owner and authorities having jurisdiction.
 - 1. Weekend Hours: 7 a.m. to 5 p.m., or as coordinated with Owner.
 - 2. Early Morning Hours: Coordinate with Owner and authorities having jurisdiction for restrictions on noisy work.
 - 3. Work in Existing Building: If Owner will be restricted from use of certain areas of the building, notify and coordinate with Owner 72 hours in advance.
 - 4. Hours for Utility Shutdowns: Utility shutdowns to occur on weekends or off hours unless coordinated with Owner beforehand. Prepare schedule indicating anticipated shut down periods for Owner to plan accordingly.
 - a. The University will provide a fire watch if necessary for utilities to be down overnight.
 - 5. Hours for Core Drilling and other noisy activities: 7a.m.-5 p.m., coordinate with Owner.
- C. Existing Utility Interruptions: Do not interrupt utilities serving facilities occupied by Owner or others unless permitted under the following conditions and then only after arranging for temporary utility services according to requirements indicated:
 - 1. Notify Owner not less than two days in advance of proposed utility interruptions.
- D. Noise, Vibration, Dust, and Odors: Coordinate operations that may result in high levels of noise and vibration, dust, odors, or other disruption to Owner occupancy with Owner.
 - 1. Notify Owner not less than two days in advance of proposed disruptive operations.
- E. Smoking and Controlled Substance Restrictions: Use of tobacco products, alcoholic beverages, and other controlled substances on Owner's property is not permitted.

1.11 SPECIFICATION AND DRAWING CONVENTIONS

- A. Specification Content: The Specifications use certain conventions for the style of language and the intended meaning of certain terms, words, and phrases when used in particular situations. These conventions are as follows:
 - 1. Imperative mood and streamlined language are generally used in the Specifications. The words "shall," "shall be," or "shall comply with," depending on the context, are implied where a colon (:) is used within a sentence or phrase.
 - 2. Text Color: Text used in the Specifications, including units of measure, manufacturer and product names, and other text may appear in multiple colors or underlined as part of a hyperlink; no emphasis is implied by text with these characteristics.
 - 3. Hypertext: Text used in the Specifications may contain hyperlinks. Hyperlinks may allow for access to linked information that is not residing in the Specifications. Unless otherwise indicated, linked information is not part of the Contract Documents.
 - 4. Specification requirements are to be performed by Contractor unless specifically stated otherwise.

- B. Division 00 Contracting Requirements: General provisions of the Contract, including General and Supplementary Conditions, apply to all Sections of the Specifications.
- C. Division 01 General Requirements: Requirements of Sections in Division 01 apply to the Work of all Sections in the Specifications.
- D. Drawing Coordination: Requirements for materials and products identified on Drawings are described in detail in the Specifications. One or more of the following are used on Drawings to identify materials and products:
 - 1. Terminology: Materials and products are identified by the typical generic terms used in the individual Specifications Sections.
 - 2. Abbreviations: Materials and products are identified by abbreviations scheduled on Drawings and published as part of the U.S. National CAD Standard.
 - 3. Keynoting: Materials and products are identified by reference keynotes referencing Specification Section numbers found in this Project Manual.

1.12 MISCELLANEOUS PROVISIONS

- A. This project is subject to State of Maine Department of Labor wage determination rates. Please note that the project manual includes the 2021 rates for reference. The 2022 rates will be issued via addendum. The 2022 rates will be required for this project.

PART 2 - PRODUCTS (Not Used)

PART 3 - EXECUTION (Not Used)

END OF SECTION 01 10 00

SECTION 05 50 00
METAL FABRICATIONS

PART 1 - GENERAL

1.1 SUMMARY

A. Section Includes:

1. Steel framing, metal grating and supports for mechanical catwalk.
2. Engineered snow retention fence.
3. Steel framing and supports for mechanical and electrical equipment.
4. Steel framing and supports for applications where framing and supports are not specified in other Sections.
5. Loose bearing and leveling plates for applications where they are not specified in other Sections.

B. Products furnished, but not installed, under this Section include the following:

1. Loose steel lintels.
2. Steel weld plates and angles for casting into concrete for applications where they are not specified in other Sections.

1.2 COORDINATION

A. Coordinate selection of shop primers with topcoats to be applied over them. Comply with paint and coating manufacturers' written recommendations to ensure that shop primers and topcoats are compatible with one another.

B. Coordinate installation of metal fabrications that are anchored to or that receive other work. Furnish setting drawings, templates, and directions for installing anchorages, including sleeves, concrete inserts, anchor bolts, and items with integral anchors, that are to be embedded in concrete or masonry. Deliver such items to Project site in time for installation.

1.3 ACTION SUBMITTALS

A. Shop Drawings: Show fabrication and installation details. Include plans, elevations, sections, and details of metal fabrications and their connections. Show anchorage and accessory items. Provide Shop Drawings for the following:

1. Mechanical Catwalk.
2. Snow Retention Fence

B. Delegated-Design Submittal: Include analysis data signed and sealed by the qualified professional engineer responsible for their preparation.

1.4 INFORMATIONAL SUBMITTALS

A. Qualification Data: For professional engineer.

B. Welding certificates.

- C. Paint Compatibility Certificates: From manufacturers of topcoats applied over shop primers, certifying that shop primers are compatible with topcoats.
- 1.5 QUALITY ASSURANCE
- A. Welding Qualifications: Qualify procedures and personnel according to AWS D1.1/D1.1M, "Structural Welding Code - Steel."
- 1.6 FIELD CONDITIONS
- A. Field Measurements: Verify actual locations of walls and other construction contiguous with metal fabrications by field measurements before fabrication.

PART 2 - PRODUCTS

2.1 PERFORMANCE REQUIREMENTS

- A. Delegated Design: Engage a qualified professional engineer, as defined in Section 01 40 00 "Quality Requirements," to design steel framing and supports, mechanical catwalk and snow guard connections.
- B. Thermal Movements: Allow for thermal movements from ambient and surface temperature changes acting on exterior metal fabrications by preventing buckling, opening of joints, overstressing of components, failure of connections, and other detrimental effects.
 - 1. Temperature Change: 120 deg F, ambient; 180 deg F, material surfaces.

2.2 METALS

- A. Metal Surfaces, General: Provide materials with smooth, flat surfaces unless otherwise indicated. For metal fabrications exposed to view in the completed Work, provide materials without seam marks, roller marks, rolled trade names, or blemishes.
- B. Steel Plates, Shapes, and Bars: ASTM A 36/A 36M.
- C. Steel Tubing: ASTM A 500/A 500M, cold-formed steel tubing.
- D. Steel Pipe: ASTM A 53/A 53M, Standard Weight (Schedule 40) unless otherwise indicated.
- E. Aluminum Plate and Sheet: ASTM B209, Alloy 6061-T6.
- F. Aluminum Extrusions: ASTM B221, Alloy 6063-T6.
- G. Uni Strut support system (Uni-Strut channels): Cold-formed metal box channels (struts) complying with MFMA-4.

2.3 FASTENERS

- A. General: Unless otherwise indicated, provide Type 304 stainless-steel fasteners for exterior use and zinc-plated fasteners with coating complying with ASTM B 633 or ASTM F 1941, Class Fe/Zn 5, at exterior walls. Select fasteners for type, grade, and class required.
- B. Steel Bolts and Nuts: Regular hexagon-head bolts, ASTM A 307, Grade A; with hex nuts, ASTM A 563; and, where indicated, flat washers.

- C. Anchor Bolts: ASTM F 1554, Grade 36, of dimensions indicated; with nuts, ASTM A 563; and, where indicated, flat washers.
 - 1. Hot-dip galvanize or provide mechanically deposited, zinc coating where item being fastened is indicated to be galvanized.
- D. Anchors, General: Anchors capable of sustaining, without failure, a load equal to six times the load imposed when installed in unit masonry and four times the load imposed when installed in concrete, as determined by testing according to ASTM E 488/E 488M, conducted by a qualified independent testing agency.
- E. Cast-in-Place Anchors in Concrete: Either threaded type or wedge type unless otherwise indicated; galvanized ferrous castings, either ASTM A 47/A 47M malleable iron or ASTM A 27/A 27M cast steel. Provide bolts, washers, and shims as needed, all hot-dip galvanized per ASTM F 2329.
- F. Post-Installed Anchors: Torque-controlled expansion anchors or chemical anchors.
 - 1. Material for Interior Locations: Carbon-steel components zinc plated to comply with ASTM B 633 or ASTM F 1941, Class Fe/Zn 5, unless otherwise indicated.
 - 2. Material for Exterior Locations and Where Stainless Steel Is Indicated: Alloy Group 1 stainless-steel bolts, ASTM F 593, and nuts, ASTM F 594.

2.4 MISCELLANEOUS MATERIALS

- A. Universal Shop Primer: Fast-curing, lead- and chromate-free, universal modified-alkyd primer complying with MPI#79 and compatible with topcoat.
 - 1. Use primer containing pigments that make it easily distinguishable from zinc-rich primer.
- B. Epoxy Zinc-Rich Primer: Complying with MPI#20 and compatible with topcoat.
 - 1. Products: Subject to compliance with requirements, provide one of the following:
 - a. Benjamin Moore & Co.; Epoxy Zinc-Rich Primer CM18/19.
 - b. ICI Devco Coatings; Catha-Coat 313.
 - c. International Coatings Limited; Interzinc 315 Epoxy Zinc-Rich Primer.
 - d. PPG Architectural Finishes, Inc.; Epoxy Zinc Rich Primer 97-670.
 - e. Sherwin-Williams Company (The); Zinc Clad IV, B69A8/B69V8.
 - f. Tnemec Company, Inc.; Tneme-Zinc 90-97.
- C. Shop Primer for Galvanized Steel: Primer formulated for exterior use over zinc-coated metal and compatible with finish paint systems indicated.
- D. Galvanizing Repair Paint: High-zinc-dust-content paint complying with SSPC-Paint 20 and compatible with paints specified to be used over it.
- E. Bituminous Paint: Cold-applied asphalt emulsion complying with ASTM D 1187/D 1187M.
 - 1. Available Products:
 - a. Sealmatic, Type 1; W. R. Meadows
 - b. Hydrocide 600; Sonneborn Building Products.
 - c. Karnak 100 AF; Karnac Chemical Corp.
- F. Nonshrink, Nonmetallic Grout: Factory-packaged, nonstaining, noncorrosive, nongaseous grout complying with ASTM C 1107/C 1107M. Provide grout specifically recommended by manufacturer for interior and exterior applications.

1. Available Products:

- a. Five Star Grout by Five Star Products, Inc.
- b. Masterflow 928 Grout by Master Builders Technologies.
- c. SonogROUT 10K by Sonneborn.
- d. 14K Hy Flow by Sonneborn.

- G. Concrete: Comply with requirements in Section 03 30 00 "Cast-in-Place Concrete" for normal-weight, air-entrained, concrete with a minimum 28-day compressive strength of 3000 psi.
- H. Fabreeka Thermal Break Pads: At snow guard attachment to structure, provide ½" Fabreeka-TIM structural thermal break material available from Fabreeka, A Stabilus Company.

2.5 FABRICATION, GENERAL

- A. Shop Assembly: Preassemble items in the shop to greatest extent possible. Disassemble units only as necessary for shipping and handling limitations. Use connections that maintain structural value of joined pieces. Clearly mark units for reassembly and coordinated installation.
- B. Cut, drill, and punch metals cleanly and accurately. Remove burrs and ease edges to a radius of approximately 1/32 inch unless otherwise indicated. Remove sharp or rough areas on exposed surfaces.
- C. Form bent-metal corners to smallest radius possible without causing grain separation or otherwise impairing work.
- D. Form exposed work with accurate angles and surfaces and straight edges.
- E. Weld corners and seams continuously to comply with the following:
1. Use materials and methods that minimize distortion and develop strength and corrosion resistance of base metals.
 2. Obtain fusion without undercut or overlap.
 3. Remove welding flux immediately.
 4. At exposed connections, finish exposed welds and surfaces smooth and blended so no roughness shows after finishing and contour of welded surface matches that of adjacent surface.
- F. Form exposed connections with hairline joints, flush and smooth, using concealed fasteners or welds where possible. Where exposed fasteners are required, use Phillips flat-head (countersunk) fasteners unless otherwise indicated. Locate joints where least conspicuous.
- G. Fabricate seams and other connections that are exposed to weather in a manner to exclude water. Provide weep holes where water may accumulate.
- H. Cut, reinforce, drill, and tap metal fabrications as indicated to receive finish hardware, screws, and similar items.
- I. Provide for anchorage of type indicated; coordinate with supporting structure. Space anchoring devices to secure metal fabrications rigidly in place and to support indicated loads.

2.6 MISCELLANEOUS FRAMING AND SUPPORTS

- A. General: Provide steel framing and supports not specified in other Sections as needed to complete the Work.

- B. Fabricate units from steel shapes, plates, and bars of welded construction unless otherwise indicated. Fabricate to sizes, shapes, and profiles indicated and as necessary to receive adjacent construction.
 - 1. Fabricate units from slotted channel framing where indicated.
 - 2. Furnish inserts for units installed after concrete is placed.
 - C. Fabricate supports for operable partitions from continuous steel beams of sizes indicated with attached bearing plates, anchors, and braces as indicated. Drill or punch bottom flanges of beams to receive partition track hanger rods; locate holes where indicated on operable partition Shop Drawings.
 - D. Galvanize miscellaneous framing and supports where indicated.
 - E. Prime miscellaneous framing and supports with universal primer unless noted otherwise.
- 2.7 LOOSE BEARING AND LEVELING PLATES
- A. Provide loose bearing and leveling plates for steel items bearing on masonry or concrete construction. Drill plates to receive anchor bolts and for grouting.
 - B. Prime plates with zinc-rich primer.
- 2.8 LOOSE STEEL LINTELS
- A. Fabricate loose steel lintels from steel angles and shapes of size indicated for openings and recesses in masonry walls and partitions at locations indicated. Fabricate in single lengths for each opening unless otherwise indicated. Weld adjoining members together to form a single unit where indicated.
 - B. Size loose lintels to provide bearing length at each side of openings equal to 1/12 of clear span, but not less than 8 inches unless otherwise indicated.
 - C. Galvanize and prime loose steel lintels located in exterior walls.
- 2.9 STEEL WELD PLATES AND ANGLES
- A. Provide steel weld plates and angles not specified in other Sections, for items supported from concrete construction as needed to complete the Work. Provide each unit with no fewer than two integrally welded steel strap anchors for embedding in concrete.
- 2.10 FINISHES, GENERAL
- A. Finish metal fabrications after assembly.
 - B. Finish exposed surfaces to remove tool and die marks and stretch lines, and to blend into surrounding surface.
- 2.11 STEEL AND IRON FINISHES
- A. Galvanizing: Provide coating for iron and steel fabrications applied by the hot-dipped process, Duragalv by Duncan Galvanizing. The galvanizing bath shall contain high grade zinc and other earthly materials. Immediately before galvanizing, the steel shall be immersed in a bath of zinc ammonium chloride. The use of the wet kettle process is prohibited. Comply with ASTM A123 for fabricated products and ASTM A 153 for hardware. Provide thickness of galvanizing specified in referenced standards.
 - 1. Do not quench or apply post galvanizing treatments that might interfere with paint adhesion.

- B. Preparation for Shop Priming Galvanized Items: After galvanizing, thoroughly clean railings of grease, dirt, oil, flux, and other foreign matter, and treat with metallic phosphate process.
- C. Shop prime iron and steel items not indicated to be galvanized unless they are to be embedded in concrete, sprayed-on fireproofing, or masonry, or unless otherwise indicated.
 - 1. Shop prime with universal shop primer unless zinc-rich primer is indicated.
- D. Preparation for Shop Priming: Prepare surfaces to comply with SSPC-SP 3, "Power Tool Cleaning."
- E. Shop Priming: Apply shop primer to comply with SSPC-PA 1, "Paint Application Specification No. 1: Shop, Field, and Maintenance Painting of Steel," for shop painting.
 - 1. Stripe paint corners, crevices, bolts, welds, and sharp edges.

2.12 MECHANICAL CATWALK

- A. **Mechanical Catwalk: Provide catwalk design and engineering based upon details and requirements of architectural, mechanical and structural drawings suitable for the support of the approved mechanical unit, its accessories and maintenance personnel.**

2.13 SNOW RETENTION FENCE

- A. **Provide design and engineering for the snow retention fence indicated in the drawings. System to be designed to attach to structural roof deck with thermal break pad to minimize heat transfer through steel components. Snow guard basis of design Alpine Snow Guards PP115:**
 - 1. **Provide aluminum powder coated 2 rail model with baseplate.**
 - 2. **Provide accessories necessary for product performance such as but not limited to ice flags, ice fence, couplings, end collars and end caps.**

PART 3 - EXECUTION

3.1 INSTALLATION, GENERAL

- A. Cutting, Fitting, and Placement: Perform cutting, drilling, and fitting required for installing metal fabrications. Set metal fabrications accurately in location, alignment, and elevation; with edges and surfaces level, plumb, true, and free of rack; and measured from established lines and levels.
- B. Fit exposed connections accurately together to form hairline joints. Weld connections that are not to be left as exposed joints but cannot be shop welded because of shipping size limitations. Do not weld, cut, or abrade surfaces of exterior units that have been hot-dip galvanized after fabrication and are for bolted or screwed field connections.
- C. Field Welding: Comply with the following requirements:
 - 1. Use materials and methods that minimize distortion and develop strength and corrosion resistance of base metals.
 - 2. Obtain fusion without undercut or overlap.
 - 3. Remove welding flux immediately.
 - 4. At exposed connections, finish exposed welds and surfaces smooth and blended so no roughness shows after finishing and contour of welded surface matches that of adjacent surface.

- D. Fastening to In-Place Construction: Provide anchorage devices and fasteners where metal fabrications are required to be fastened to in-place construction. Provide threaded fasteners for use with concrete and masonry inserts, toggle bolts, through bolts, lag screws, wood screws, and other connectors.
- E. Provide temporary bracing or anchors in formwork for items that are to be built into concrete, masonry, or similar construction.

3.2 INSTALLING MISCELLANEOUS FRAMING AND SUPPORTS

- A. General: Install framing and supports to comply with requirements of items being supported, including manufacturers' written instructions and requirements indicated on Shop Drawings.

~~B. Anchor supports for operable partitions and overhead doors securely to, and rigidly brace from, building structure.~~

3.3 INSTALLING BEARING AND LEVELING PLATES

- A. Clean concrete and masonry bearing surfaces of bond-reducing materials, and roughen to improve bond to surfaces. Clean bottom surface of plates.
- B. Set bearing and leveling plates on wedges, shims, or leveling nuts. After bearing members have been positioned and plumbed, tighten anchor bolts. Do not remove wedges or shims but, if protruding, cut off flush with edge of bearing plate before packing with nonshrink grout. Pack grout solidly between bearing surfaces and plates to ensure that no voids remain.
- C. Protect grout from freezing for 7 days to allow for curing.

3.4 ADJUSTING AND CLEANING

- A. Touchup Painting: Immediately after erection, clean field welds, bolted connections, and abraded areas. Paint uncoated and abraded areas with the same material as used for shop painting to comply with SSPC-PA 1 for touching up shop-painted surfaces.
 - 1. Apply by brush or spray to provide a minimum 2.0-mil dry film thickness.
- B. Galvanized Surfaces: Clean field welds, bolted connections, and abraded areas and repair galvanizing to comply with ASTM A 780/A 780M.

END OF SECTION 05 50 00

SECTION 07 53 23
ETHYLENE-PROPYLENE-DIENE-MONOMER (EPDM) ROOFING

PART 1 - GENERAL

1.1 RELATED DOCUMENTS

- A. Drawings and general provisions of the Contract, including General and Supplementary Conditions and Division 01 Specification Sections, apply to this Section.

1.2 SUMMARY

- A. Section Includes:

1. Adhered ethylene-propylene-diene-monomer (EPDM) roofing system.
2. Vapor retarder.
3. Roof insulation.
4. **See Section 055000 for snow guards.**

1.3 DEFINITIONS

- A. Roofing Terminology: Definitions in ASTM D 1079 and glossary of NRCA's "The NRCA Roofing and Waterproofing Manual" apply to work of this Section.

1.4 PREINSTALLATION MEETINGS

- A. Preinstallation Roofing Conference: Conduct conference at Project site.

1. Meet with Owner, Architect (virtually), Owner's insurer if applicable, testing and inspecting agency representative, roofing Installer, roofing system manufacturer's representative, deck Installer, and installers whose work interfaces with or affects roofing, including installers of roof accessories and roof-mounted equipment.
2. Review methods and procedures related to roofing installation, including manufacturer's written instructions and procedure to maintain a weathertight building during construction.
3. Review starting and stopping sequencing including process for keeping installed materials free of water and moisture.
4. Review and finalize construction schedule, and verify availability of materials, Installer's personnel, equipment, and facilities needed to make progress and avoid delays.
5. Examine deck substrate conditions and finishes for compliance with requirements, including flatness and fastening.
6. Review fastening procedures to eliminate visible fasteners from the visible side of the roof deck.
7. Review structural loading limitations of roof deck during and after roofing.
8. Review base flashings, special roofing details, roof drainage, roof penetrations, equipment curbs, and condition of other construction that affects roofing system.
9. Review governing regulations and requirements for insurance and certificates if applicable.
10. Review temporary protection requirements for roofing system during and after installation.
11. Review roof observation and repair procedures after roofing installation.

1.5 ACTION SUBMITTALS

- A. Product Data: For each type of product.
 - B. Shop Drawings: For roofing system. Include plans, elevations, sections, details, and attachments to other work, including:
 - 1. Layout of membrane joints.
 - 2. Base flashings and membrane terminations.
 - 3. Roof plan showing orientation of steel roof deck and orientation of roofing, fastening spacings, and patterns for mechanically fastened roofing.
 - 4. **Layout and details of snowguards. Coordinate with 055000. Provide water cut off mastics, membrane target patch and additional lap flashing at high side of units.**
 - 5. Insulation fastening patterns for corner, perimeter, and field-of-roof locations.
 - 6. Description of installation process including starting and stopping procedures.
 - C. Samples for Verification: For the following products:**
 - 1. Sheet roofing, of color required.**
 - D. Manufacturer's Roof Assembly Letter:
 - 1. List products used, wind rating, warranty terms and required fastening as part of complete roof assembly and total roof assembly warranty.
- 1.6 INFORMATIONAL SUBMITTALS
- A. Qualification Data: For Installer and manufacturer.
 - B. Product Test Reports: For components of roofing system, tests performed by manufacturer and witnessed by a qualified testing agency.
- 1.7 CLOSEOUT SUBMITTALS
- A. Product and Maintenance Data: For roofing system to include in maintenance manuals.
- 1.8 QUALITY ASSURANCE
- A. Installer Qualifications: A qualified firm that is approved, authorized, or licensed by roofing system manufacturer to install manufacturer's product and that is eligible to receive manufacturer's special warranty.
- 1.9 DELIVERY, STORAGE, AND HANDLING
- A. Deliver roofing materials to Project site in original containers with seals unbroken and labeled with manufacturer's name, product brand name and type, date of manufacture, approval or listing agency markings, and directions for storing and mixing with other components.
 - B. Store liquid materials in their original undamaged containers in a clean, dry, protected location and within the temperature range required by roofing system manufacturer. Protect stored liquid material from direct sunlight.
 - 1. Discard and legally dispose of liquid material that cannot be applied within its stated shelf life.

- C. Protect roof insulation materials from physical damage and from deterioration by sunlight, moisture, soiling, and other sources. Store in a dry location. Comply with insulation manufacturer's written instructions for handling, storing, and protecting during installation.
- D. Handle and store roofing materials, and place equipment in a manner to avoid permanent deflection of deck.

1.10 FIELD CONDITIONS

- A. Weather Limitations: Proceed with installation only when existing and forecasted weather conditions permit roofing system to be installed according to manufacturer's written instructions and warranty requirements.

1.11 WARRANTY

- A. Special Warranty: Manufacturer agrees to repair or replace components of roofing system that fail in materials or workmanship within specified warranty period.
 - 1. Special warranty includes membrane roofing, base flashings, roof insulation, fasteners, cover boards, roofing accessories, roof pavers, and other components of roofing system.
 - 2. Warranty Period: 20 years from date of Substantial Completion.
- B. Special Installer's Warranty: Installer agrees to repair or replace assembly or parts of the assembly, including accessories, that fail in materials and workmanship within 2 years from the date of substantial completion.

PART 2 - PRODUCTS

2.1 MANUFACTURERS

- A. Source Limitations: Obtain components including roof insulation and fasteners for roofing system from same manufacturer as membrane roofing manufacturer approved by membrane roofing manufacturer.

2.2 PERFORMANCE REQUIREMENTS

- A. General Performance: Installed roofing and base flashings shall withstand specified uplift pressures, thermally induced movement, and exposure to weather without failure due to defective manufacture, fabrication, installation, or other defects in construction. Roofing and base flashings shall remain watertight.
 - 1. Accelerated Weathering: Roofing system shall withstand 2000 hours of exposure when tested according to ASTM G 152, ASTM G 154, or ASTM G 155.
 - 2. Impact Resistance: Roofing system shall resist impact damage when tested according to ASTM D 3746 or ASTM D 4272.
- B. Material Compatibility: Roofing materials shall be compatible with one another and adjacent materials under conditions of service and application required, as demonstrated by roofing manufacturer based on testing and field experience.
- C. Aesthetic Criteria: Membrane and flashings shall be installed in clean and uniform manner due to the highly visible nature of the University's roof to adjacent buildings and pedestrians.
 - 1. **Lines of joints/seams in membrane shall be perpendicular to roof edges.**

2. Adhesives, primers, mastics and sealants shall be installed with consistent volume, with minimum visual exposure as permitted by manufacturer.
3. Utilize factory applied tape, wherever possible and install the widest sheet size available, preferably 30' or greater.

D. Wind Uplift:

1. Roofing System Design: Provide a roofing system designed to resist uplift pressures calculated according to the current edition of the ASCE-7 Specification Minimum Design Loads for Buildings And Other Structures.

2.3 EPDM ROOFING

A. EPDM: ASTM D 4637, Type II, scrim or fabric internally reinforced non-reinforced, uniform, flexible EPDM sheet.

1. Manufacturers: Subject to compliance with requirements, available manufacturers offering products that may be incorporated into the Work include, but are not limited to, the following:
 - a. Carlisle SynTec Incorporated.
 - b. Firestone Building Products.
 - c. GAF Materials Corporation.
 - d. GenFlex Roofing Systems.
 - e. Johns Manville.
2. Thickness: 60 mils (1.5 mm) nominal.
3. Color: Grey, Black

2.4 AUXILIARY ROOFING MATERIALS

- A. General: Auxiliary materials recommended by roofing system manufacturer for intended use and compatible with roofing.
1. Liquid-type auxiliary materials shall comply with VOC limits of authorities having jurisdiction.
- B. Sheet Flashing: 60-mil-thick EPDM, partially cured or cured, according to application.
- C. Bonding Adhesive: Manufacturer's standard.
- D. Seaming Material: Single-component, butyl splicing adhesive and splice cleaner Manufacturer's standard, synthetic-rubber polymer primer and 3-inch-wide minimum, butyl splice tape with release film.
- E. Lap Sealant: Manufacturer's standard, single-component sealant, colored to match membrane roofing.
- F. Water Cutoff Mastic: Manufacturer's standard butyl mastic sealant.
- G. Metal Termination Bars: Manufacturer's standard, predrilled stainless-steel or aluminum bars, approximately 1 by 1/8 inch thick; with anchors.
- H. Fasteners: Factory-coated steel fasteners and metal or plastic plates complying with corrosion-resistance provisions in FM Global 4470, designed for fastening membrane to substrate, and acceptable to roofing system manufacturer.

- I. Miscellaneous Accessories: Provide pourable sealers, preformed cone and vent sheet flashings, molded pipe boot flashings, preformed inside and outside corner sheet flashings, reinforced EPDM se-curement strips, T-joint covers, in-seam sealants, termination reglets, cover strips, and other accesso-ries.

2.5 VAPOR RETARDER

- A. Self-Adhering-Sheet Vapor Retarder for Metal Deck: Polyethylene film laminated to layer of butyl rubber adhesive, minimum 15-mil-total thickness; maximum permeance rating of 0.03 perm; cold ap-plied over metal roof deck.
 - 1. Carlisle: VapAir Seal MD.
 - 2. Sarnavap SA. (32mil)
 - 3. Duro-Last Vapor Barrier (32 mil)

2.6 ROOF INSULATION

- A. General: Preformed roof insulation boards approved by EPDM roofing manufacturer, selected from manufacturer's standard sizes suitable for application, of thicknesses indicated.
- B. Base Bid: Extruded Polystyrene Board, Type IV: ASTM C 578, Type IV, 25-psi minimum compres-sive strength; unfaced; maximum flame-spread and smoke-developed indexes of 25 and 450, respec-tively, per ASTM E 84.
 - 1. Manufacturers: Subject to compliance with roofing manufacturer's requirements, provide products by one of the following or others as approved by Architect:
 - a. Dow Chemical Company (The); Styrofoam Square Edge Insulation.
 - b. Owens Corning; Foamular® 250.
 - c. KingSpan; GreenGuard Type IV 25 PSI Insulation Board.
 - 1) R-Value: 5.0 per inch.
 - 2) Thickness: Minimum 3 layers of 2" insulation with staggered joints and as indi-cated on the drawings.
- C. Alternate: Polyisocyanurate Board Insulation: ASTM C 1289, Type II, Class 1, Grade 3, felt or glass-fiber mat facer on both major surfaces.
 - 1. Thickness: Minimum 3 layers of 2" insulation with staggered joints and as indicated on the drawings.

2.7 INSULATION ACCESSORIES

- A. General: Roof insulation accessories recommended by insulation manufacturer for intended use and compatibility with roofing.
- B. Cover Board:
 - 1. Products: Subject to compliance with requirements, provide the following:
 - a. Georgia-Pacific Corporation; Dens Deck Prime **or approved equal.**
 - b. Carlisle Syntec Secure Shield HD Plus Polyiso **or approved equal** if compatible with base bid roof insulation. ***This product is a University of Maine System standard and is its preference.***

PART 3 - EXECUTION

3.1 EXAMINATION

- A. Examine substrates, areas, and conditions, with Installer present, for compliance with requirements and other conditions affecting performance of the Work:
 - 1. Verify that roof openings and penetrations are in place, curbs are set and braced, and roof-drain bodies are securely clamped in place.
 - 2. Verify that wood blocking, curbs, and nailers are securely anchored to roof deck at penetrations and terminations and that nailers match thicknesses of insulation.
 - 3. Verify that surface plane flatness and fastening of steel roof deck complies with requirements in Section 05 31 00 "Steel Decking."
- B. Proceed with installation only after unsatisfactory conditions have been corrected.

3.2 PREPARATION

- A. Clean substrate of dust, debris, moisture, and other substances detrimental to roofing installation according to roofing system manufacturer's written instructions. Remove sharp projections.
- B. Prevent materials from entering and clogging roof drains and conductors and from spilling or migrating onto surfaces of other construction. Remove roof-drain plugs when no work is taking place or when rain is forecast.

3.3 ROOFING INSTALLATION, GENERAL

- A. Install roofing system according to roofing system manufacturer's written instructions.
- B. Complete terminations and base flashings and provide temporary seals to prevent water from entering completed sections of roofing system at the end of the workday or when rain is forecast. Remove and discard temporary seals before beginning work on adjoining roofing.

3.4 INSULATION INSTALLATION

- A. Coordinate installing roofing system components so insulation is not exposed to precipitation or left exposed at the end of the workday.
- B. Comply with roofing system and insulation manufacturer's written instructions for installing roof insulation.
- C. Install tapered insulation under area of roofing to conform to slopes indicated.
- D. Install insulation under area of roofing to achieve required thickness. Where overall insulation thickness is 2.7 inches or greater, install two or more layers with joints of each succeeding layer staggered from joints of previous layer a minimum of 6 inches in each direction.
 - 1. Where installing composite and noncomposite insulation in two or more layers, install noncomposite board insulation for bottom layer and intermediate layers, if applicable, and install composite board insulation for top layer.
- E. Install insulation with long joints of insulation in a continuous straight line with end joints staggered between rows, abutting edges and ends between boards. Fill gaps exceeding 1/8 inch with insulation.

1. Cut and fit insulation within 1/8 inch of nailers, projections, and penetrations.

3.5 VAPOR-RETARDER INSTALLATION

- A. Self-Adhering-Sheet Vapor Retarder: Prime substrate if required by manufacturer. Install self-adhering-sheet vapor retarder over area to receive vapor retarder, side and end lapping each sheet a minimum of 3-1/2 inches and 6 inches, respectively. Seal laps by rolling.
- B. Completely seal vapor retarder at terminations, obstructions, and penetrations to prevent air movement into roofing system.

3.6 ADHERED MEMBRANE ROOFING INSTALLATION

- A. Adhere roofing over area to receive roofing according to membrane roofing system manufacturer's written instructions. Unroll membrane roofing and allow to relax before installing.
- B. Start installation of roofing in presence of roofing system manufacturer's technical personnel.
- C. Accurately align roofing, and maintain uniform side and end laps of minimum dimensions required by manufacturer. Stagger end laps.
- D. Bonding Adhesive: Apply to substrate and underside of roofing at rate required by manufacturer, and allow to partially dry before installing roofing. Do not apply to splice area of roofing.
- E. In addition to adhering, mechanically fasten roofing securely at terminations, penetrations, and perimeters.
- F. Apply roofing with side laps shingled with slope of roof deck where possible.
- G. Adhesive Seam Installation: Clean both faces of splice areas, apply splicing cement, and firmly roll side and end laps of overlapping roofing according to manufacturer's written instructions to ensure a watertight seam installation. Apply lap sealant and seal exposed edges of roofing terminations.
- H. Repair tears, voids, and lapped seams in roofing that do not comply with requirements.
- I. Spread sealant or mastic bed over deck-drain flange at roof drains, and securely seal membrane roofing in place with clamping ring.

3.7 BASE FLASHING INSTALLATION

- A. Install sheet flashings and preformed flashing accessories, and adhere to substrates according to roofing system manufacturer's written instructions.
- B. Apply bonding adhesive to substrate and underside of sheet flashing at required rate, and allow to partially dry. Do not apply to seam area of flashing.
- C. Flash penetrations and field-formed inside and outside corners with cured or uncured sheet flashing.
- D. Clean splice areas, apply splicing cement, and firmly roll side and end laps of overlapping sheets to ensure a watertight seam installation. Apply lap sealant and seal exposed edges of sheet flashing terminations.
- E. Terminate and seal top of sheet flashings and mechanically anchor to substrate through termination bars.

3.8 FIELD QUALITY CONTROL

- ~~A. Testing Agency: Engage a qualified testing agency to inspect substrate conditions, surface preparation, membrane application, flashings, protection, and drainage components, and to furnish reports to Architect.~~
- ~~B. Final Roof Inspection: Arrange for roofing system manufacturer's technical personnel to inspect roofing installation on completion.~~
- ~~C. Repair or remove and replace components of roofing system where inspections indicate that they do not comply with specified requirements.~~
- ~~D. Additional testing and inspecting, at Contractor's expense, will be performed to determine if re-placed or additional work complies with specified requirements.~~
- E. Initial Roof Inspection: Arrange for roofing system manufacturer's technical personnel to inspect roofing installation on completion with Owner.
 - I. Notify Architect or Owner 48 hours in advance of the date and time of inspection.
- F. Final Roof Inspection: Arrange for roofing system manufacturer's technical personnel to inspect roofing installation after initial roof inspection repairs are completed.
 - I. Notify Architect or Owner 48 hours in advance of the date and time of inspection.
- G. Repair or remove and replace components of roofing system where inspections indicate that they do not comply with specified requirements.

3.9 PROTECTING AND CLEANING

- A. Protect membrane roofing system from damage and wear during remainder of construction period. When remaining construction does not affect or endanger roofing, inspect roofing for deterioration and damage, describing its nature and extent in a written report, with copies to Architect and Owner.
- B. Correct deficiencies in or remove membrane roofing system that does not comply with requirements, repair substrates, and repair or reinstall membrane roofing system to a condition free of damage and deterioration at time of Substantial Completion and according to warranty requirements.

3.10 ROOFING INSTALLER'S WARRANTY

- A. WHEREAS _____ of _____, herein called the "Roofing Installer," has performed roofing and associated work ("work") on the following project:
 - 1. Owner:
 - 2. Address:
 - 3. Building Name/Type:
 - 4. Address:
 - 5. Area of Work:
 - 6. Acceptance Date:
 - 7. Warranty Period:
 - 8. Expiration Date:

- B. AND WHEREAS Roofing Installer has contracted (either directly with Owner or indirectly as a subcontractor) to warrant said work against leaks and faulty or defective materials and workmanship for designated Warranty Period,
- C. NOW THEREFORE Roofing Installer hereby warrants, subject to terms and conditions herein set forth, that during Warranty Period Roofing Installer will, at Roofing Installer's own cost and expense, make or cause to be made such repairs to or replacements of said work as are necessary to correct faulty and defective work and as are necessary to maintain said work in a watertight condition.
- D. This Warranty is made subject to the following terms and conditions:
1. Specifically excluded from this Warranty are damages to work and other parts of the building, and to building contents, caused by:
 - a. lightning;
 - b. Insert required wind speed in first subparagraph below.
 - c. peak gust wind speed exceeding ~~100~~ **90** mph;
 - d. fire;
 - e. activity on roofing by others, including construction contractors, maintenance personnel, other persons, and animals, whether authorized or unauthorized by Owner.
 2. When work has been damaged by any of foregoing causes, Warranty shall be null and void until such damage has been repaired by Roofing Installer and until cost and expense thereof have been paid by Owner or by another responsible party so designated.
 3. Roofing Installer is responsible for damage to work covered by this Warranty but is not liable for consequential damages to building or building contents resulting from leaks or faults or defects of work.
 4. During Warranty Period, if Owner allows alteration of work by anyone other than Roofing Installer, including cutting, patching, and maintenance in connection with penetrations, attachment of other work, and positioning of anything on roof, this Warranty shall become null and void on date of said alterations, but only to the extent said alterations affect work covered by this Warranty. If Owner engages Roofing Installer to perform said alterations, Warranty shall not become null and void unless Roofing Installer, before starting said work, shall have notified Owner in writing, showing reasonable cause for claim, that said alterations would likely damage or deteriorate work, thereby reasonably justifying a limitation or termination of this Warranty.
 5. During Warranty Period, if original use of roof is changed and it becomes used for, but was not originally specified for, a promenade, work deck, spray-cooled surface, flooded basin, or other use or service more severe than originally specified, this Warranty shall become null and void on date of said change, but only to the extent said change affects work covered by this Warranty.
 6. Owner shall promptly notify Roofing Installer of observed, known, or suspected leaks, defects, or deterioration and shall afford reasonable opportunity for Roofing Installer to inspect work and to examine evidence of such leaks, defects, or deterioration.
 7. This Warranty is recognized to be the only warranty of Roofing Installer on said work and shall not operate to restrict or cut off Owner from other remedies and resources lawfully available to Owner in cases of roofing failure. Specifically, this Warranty shall not operate to relieve Roofing Installer of responsibility for performance of original work according to requirements of the Contract Documents, regardless of whether Contract was a contract directly with Owner or a subcontract with Owner's General Contractor.
- E. IN WITNESS THEREOF, this instrument has been duly executed this _____ day of _____, _____.
1. Authorized Signature: _____.
 2. Name: _____.
 3. Title: _____.

END OF SECTION 07 53 23

SECTION 07 54 19
POLYVINYL-CHLORIDE (PVC) ROOFING

PART 1 - GENERAL

1.1 SUMMARY

A. Section Includes:

1. Adhered polyvinyl-chloride (PVC) roofing system.
2. Vapor retarder.
3. Roof insulation.
4. ***See Section 055000 for snow guards.***

1.2 DEFINITIONS

- A. Roofing Terminology: Definitions in ASTM D 1079 and glossary in NRCA's "The NRCA Roofing and Waterproofing Manual" apply to work of this Section.

1.3 PREINSTALLATION MEETINGS

A. Preinstallation Roofing Conference: Conduct conference at Project site.

1. Meet with Owner, Architect (virtually), Owner's insurer if applicable, testing and inspecting agency representative, roofing Installer, roofing system manufacturer's representative, deck Installer, and installers whose work interfaces with or affects roofing, including installers of roof accessories and roof-mounted equipment.
2. Review methods and procedures related to roofing installation, including manufacturer's written instructions and procedure to maintain a weathertight building during construction.
3. Review starting and stopping sequencing including process for keeping installed materials free of water and moisture.
4. Review and finalize construction schedule, and verify availability of materials, Installer's personnel, equipment, and facilities needed to make progress and avoid delays.
5. Examine deck substrate conditions and finishes for compliance with requirements, including flatness and fastening.
6. Review fastening procedures to eliminate visible fasteners from the visible side of the roof deck.
7. Review structural loading limitations of roof deck during and after roofing.
8. Review base flashings, special roofing details, roof drainage, roof penetrations, equipment curbs, and condition of other construction that affects roofing system.
9. Review governing regulations and requirements for insurance and certificates if applicable.
10. Review temporary protection requirements for roofing system during and after installation.
11. Review roof observation and repair procedures after roofing installation.

1.4 ACTION SUBMITTALS

A. Product Data: For each type of product.

B. Shop Drawings: For roofing system. Include plans, elevations, sections, details, and attachments to other work, including:

1. Layout of membrane joints.

2. Base flashings and membrane terminations.
3. Roof plan showing orientation of steel roof deck and orientation of roofing, fastening spacings, and patterns for mechanically fastened roofing.
4. **Layout and details of snowguards. Coordinate with 055000. Provide water cut off mastics, membrane target patch and additional lap flashing at high side of units.**
5. Insulation fastening patterns for corner, perimeter, and field-of-roof locations.
6. Description of installation process including starting and stopping procedures.

C. Samples for Verification: For the following products:

1. Sheet roofing, of color required.

D. Manufacturer's Roof Assembly Letter:

1. List products used, wind rating, warranty terms and required fastening as part of complete roof assembly and total roof assembly warranty.

1.5 INFORMATIONAL SUBMITTALS

A. Qualification Data: For Installer and manufacturer.

B. Manufacturer Certificates: Signed by roofing manufacturer certifying that roofing system complies with requirements specified in "Performance Requirements" Article.

1. Submit evidence of compliance with performance requirements.

1.6 CLOSEOUT SUBMITTALS

A. Product and Maintenance Data: For roofing system to include in maintenance manuals.

1.7 QUALITY ASSURANCE

A. Installer Qualifications: A qualified firm that is approved, authorized, or licensed by roofing system manufacturer to install manufacturer's product and that is eligible to receive manufacturer's special warranty.

1.8 DELIVERY, STORAGE, AND HANDLING

A. Deliver roofing materials to Project site in original containers with seals unbroken and labeled with manufacturer's name, product brand name and type, date of manufacture, approval or listing agency markings, and directions for storing and mixing with other components.

B. Store liquid materials in their original undamaged containers in a clean, dry, protected location and within the temperature range required by roofing system manufacturer. Protect stored liquid material from direct sunlight.

1. Discard and legally dispose of liquid material that cannot be applied within its stated shelf life.

C. Protect roof insulation materials from physical damage and from deterioration by sunlight, moisture, soiling, and other sources. Store in a dry location. Comply with insulation manufacturer's written instructions for handling, storing, and protecting during installation.

D. Handle and store roofing materials, and place equipment in a manner to avoid permanent deflection of deck.

1.9 FIELD CONDITIONS

- A. Weather Limitations: Proceed with installation only when existing and forecasted weather conditions permit roofing system to be installed according to manufacturer's written instructions and warranty requirements.

1.10 WARRANTY

- A. Special Warranty: Manufacturer agrees to repair or replace components of roofing system that fail in materials or workmanship within specified warranty period.
 - 1. Special warranty includes membrane roofing, base flashings, roof insulation, fasteners, cover boards, roofing accessories, roof pavers, and other components of roofing system.
 - 2. Warranty Period: 20 years from date of Substantial Completion.
- B. Special Installer's Warranty: Installer agrees to repair or replace assembly or parts of the assembly, including accessories, that fail in materials and workmanship within 2 years from the date of substantial completion.

PART 2 - PRODUCTS

2.1 PERFORMANCE REQUIREMENTS

- A. General Performance: Installed roofing and base flashings shall withstand specified uplift pressures, thermally induced movement, and exposure to weather without failure due to defective manufacture, fabrication, installation, or other defects in construction. Roofing and base flashings shall remain watertight.
 - 1. Accelerated Weathering: Roofing system shall withstand 2000 hours of exposure when tested according to ASTM G 152, ASTM G 154, or ASTM G 155.
 - 2. Impact Resistance: Roofing system shall resist impact damage when tested according to ASTM D 3746 or ASTM D 4272.
- B. Material Compatibility: Roofing materials shall be compatible with one another and adjacent materials under conditions of service and application required, as demonstrated by roofing manufacturer based on testing and field experience.
- C. Aesthetic Criteria: Membrane and flashings shall be installed in clean and uniform manner due to the highly visible nature of the University's roof to adjacent buildings and pedestrians.
 - 1. **Lines of joints/seams in membrane shall be parallel to roof edges.**
 - 2. **Utilize the widest sheet size available, preferably 10' or greater.**
- D. Wind Uplift:
 - 1. Roofing System Design: Provide a roofing system designed to resist uplift pressures calculated according to the current edition of the ASCE-7 Specification Minimum Design Loads for Buildings and Other Structures.

2.2 PVC ROOFING

- A. PVC Sheet: ASTM D 4434/D 4434M, Type II or Type III.
 - 1. Manufacturers: Subject to compliance with requirements, provide products by one of the following:

- a. Carlisle SynTec Incorporated; Sure-Flex 60-mil PVC (Polyvinyl Chloride) Polyester Reinforced Membrane.
 - b. Duro-Last; DL60.
 - c. Sika Sarnafil G 410 membrane.
 - d. Other manufacturer's may be acceptable pending substitution request during bidding. Provide data showing that proposed system matches the performance requirements of the Carlisle Sure Flex 60-mil PVC Reinforced Membrane.
2. Thickness: 60 mils, nominal.
 3. Color: **Dark** Gray.

2.3 AUXILIARY ROOFING MATERIALS

- A. General: Auxiliary materials recommended by roofing system manufacturer for intended use and compatible with roofing.
 1. Liquid-type auxiliary materials shall comply with VOC limits of authorities having jurisdiction.
- B. Sheet Flashing: Manufacturer's standard sheet flashing of same material, type, reinforcement, thickness, and color as PVC sheet.
- C. Bonding Adhesive: Manufacturer's standard, State of Maine VOC Compliant.
- D. Water-Based, Fabric-Backed Membrane Adhesive: Roofing system manufacturer's standard water-based, cold-applied adhesive formulated for compatibility and use with fabric-backed membrane roofing.
- E. Slip Sheet: Manufacturer's standard, of thickness required for application.
- F. Metal Termination Bars: Manufacturer's standard, predrilled stainless-steel or aluminum bars, approximately 1 by 1/8 inch thick; with anchors.
- G. Fasteners: Factory-coated steel fasteners and metal or plastic plates complying with corrosion-resistance provisions in FM Global 4470, designed for fastening roofing to substrate, and acceptable to roofing system manufacturer.
- H. Miscellaneous Accessories: Provide pourable sealers, preformed cone and vent sheet flashings, preformed inside and outside corner sheet flashings, T-joint covers, lap sealants, termination reglets, and other accessories.

2.4 VAPOR RETARDER

- A. Self-Adhering-Sheet Vapor Retarder for Metal Deck: Polyethylene film laminated to layer of butyl rubber adhesive, minimum 15-mil-total thickness; maximum permeance rating of 0.03 perm; cold applied over metal roof deck.
 1. Carlisle: VapAir Seal MD.
 2. Sarnavap SA. (32mil)
 3. Duro-Last Vapor Barrier (32 mil)

2.5 ROOF INSULATION

- A. Base Bid: Extruded Polystyrene Board, Type IV: ASTM C 578, Type IV, 25-psi minimum compressive strength; unfaced; maximum flame-spread and smoke-developed indexes of 25 and 450, respectively, per ASTM E 84.
1. Manufacturers: Subject to compliance with roofing manufacturer's requirements, provide products by one of the following or others as approved by Architect:
 - a. Dow Chemical Company (The); Styrofoam Square Edge Insulation.
 - b. Owens Corning; Foamular® 250.
 - c. KingSpan; GreenGuard Type IV 25 PSI Insulation Board.
 2. R-Value: 5.0 per inch.
 3. Thickness: Minimum 3 layers of 2" insulation with staggered joints and as indicated on the drawings.
- B. Alternate: Polyisocyanurate Board Insulation: ASTM C 1289, Type II, Class 1, Grade 2, felt or glass-fiber mat facer on both major surfaces.
1. Thickness: Minimum 3 layers of 2" insulation with staggered joints and as indicated on the drawings.
- C. Tapered Insulation: Provide factory-tapered insulation boards fabricated to slope of 1/4 inch per 12 inches unless otherwise indicated.
- D. Provide preformed saddles, crickets, tapered edge strips, and other insulation shapes where indicated for sloping to drain. Fabricate to slopes indicated.

2.6 INSULATION ACCESSORIES

- A. General: Roof insulation accessories recommended by insulation manufacturer for intended use and compatibility with roofing.
- B. Fasteners: Factory-coated steel fasteners and metal or plastic plates complying with corrosion-resistance provisions in FM Global 4470, designed for fastening roof insulation and protection boards to substrate, and acceptable to roofing system manufacturer.
- C. Cover Board:
1. Products: Subject to compliance with requirements, provide the following:
 - a. Georgia-Pacific Corporation; Dens Deck Prime **or approved equal.**
 - b. Carlisle Syntec Secure Shield HD Plus Polyiso **or approved equal** if compatible with base bid roof insulation. ***This product is a University of Maine System standard and is its preference.***

PART 3 - EXECUTION

3.1 EXAMINATION

- A. Examine substrates, areas, and conditions, with Installer present, for compliance with requirements and other conditions affecting performance of the Work:
1. Verify that roof openings and penetrations are in place, curbs are set and braced, and roof-drain bodies are securely clamped in place.

2. Verify that wood blocking, curbs, and nailers are securely anchored to roof deck at penetrations and terminations and that nailers match thicknesses of insulation.
 3. Verify that surface plane flatness and fastening of steel roof deck complies with requirements in Section 05 31 00 "Steel Decking."
 4. Verify that minimum concrete drying period recommended by roofing system manufacturer has passed.
 5. Verify that concrete substrate is visibly dry and free of moisture. Test for capillary moisture by plastic sheet method according to ASTM D 4263.
 6. Verify that concrete-curing compounds that will impair adhesion of roofing components to roof deck have been removed.
- B. Proceed with installation only after unsatisfactory conditions have been corrected.
- 3.2 PREPARATION
- A. Clean substrate of dust, debris, moisture, and other substances detrimental to roofing installation according to roofing system manufacturer's written instructions. Remove sharp projections.
 - B. Prevent materials from entering and clogging roof drains and conductors and from spilling or migrating onto surfaces of other construction. Remove roof-drain plugs when no work is taking place or when rain is forecast.
 - C. Install insulation strips according to acoustical roof deck manufacturer's written instructions.
- 3.3 ROOFING INSTALLATION, GENERAL
- A. Install roofing system according to roofing system manufacturer's written instructions.
 - B. Complete terminations and base flashings and provide temporary seals to prevent water from entering completed sections of roofing system at end of workday or when rain is forecast. Remove and discard temporary seals before beginning work on adjoining roofing.
 - C. Install roofing and auxiliary materials to tie into existing roofing to maintain weathertightness of transition.
- 3.4 VAPOR-RETARDER INSTALLATION
- A. Self-Adhering-Sheet Vapor Retarder: Prime substrate if required by manufacturer. Install self-adhering-sheet vapor retarder over area to receive vapor retarder, side and end lapping each sheet a minimum of 3-1/2 inches and 6 inches, respectively. Seal laps by rolling.
 - B. Completely seal vapor retarder at terminations, obstructions, and penetrations to prevent air movement into roofing system.
- 3.5 INSULATION INSTALLATION
- A. Coordinate installing roofing system components so insulation is not exposed to precipitation or left exposed at the end of the workday.
 - B. Comply with roofing system and insulation manufacturer's written instructions for installing roof insulation.
 - C. Install tapered insulation under area of roofing to conform to slopes indicated.

- D. Install insulation under area of roofing to achieve required thickness. Where overall insulation thickness is 2.7 inches or greater, install two or more layers with joints of each succeeding layer staggered from joints of previous layer a minimum of 6 inches in each direction.
 - 1. Where installing composite and noncomposite insulation in two or more layers, install noncomposite board insulation for bottom layer and intermediate layers, if applicable, and install composite board insulation for top layer.
- E. Install insulation with staggered between rows, abutting edges and ends between boards. Fill gaps exceeding 1/8 inch with compatible minimal expanding insulation.
 - 1. Cut and fit insulation within 1/8 inch of nailers, projections, and penetrations.
- F. Loosely Laid Insulation: Loosely lay insulation units over substrate.
- G. Install protection boards over insulation with long joints in continuous straight lines with end joints staggered between rows. Offset joints of insulation below a minimum of 6 inches in each direction. Loosely butt cover boards together and fasten to roof deck.

3.6 ADHERED ROOFING INSTALLATION

- A. Adhere roofing over area to receive roofing according to roofing system manufacturer's written instructions. Unroll roofing and allow to relax before retaining.
 - 1. Install sheet according to ASTM D 5036.
- B. Start installation of roofing in presence of roofing system manufacturer's technical personnel.
- C. Accurately align roofing, and maintain uniform side and end laps of minimum dimensions required by manufacturer. Stagger end laps.
- D. Bonding Adhesive: Apply to substrate and underside of roofing at rate required by manufacturer, and allow to partially dry before installing roofing. Do not apply to splice area of roofing.
- E. In addition to adhering, mechanically fasten roofing securely at terminations, penetrations, and perimeter of roofing.
- F. Apply roofing with side laps shingled with slope of roof deck where possible.
- G. Seams: Clean seam areas, overlap roofing, and hot-air weld side and end laps of roofing and sheet flashings according to manufacturer's written instructions, to ensure a watertight seam installation.
 - 1. Test lap edges with probe to verify seam weld continuity. Apply lap sealant to seal cut edges of sheet.
 - 2. Verify field strength of seams a minimum of twice daily, and repair seam sample areas.
 - 3. Repair tears, voids, aesthetic blemishes and lapped seams in roofing that do not comply with requirements.

3.7 BASE FLASHING INSTALLATION

- A. Install sheet flashings and preformed flashing accessories, and adhere to substrates according to roofing system manufacturer's written instructions.
- B. Apply bonding adhesive to substrate and underside of sheet flashing at required rate, and allow to partially dry. Do not apply to seam area of flashing.

- C. Flash penetrations and field-formed inside and outside corners with cured or uncured sheet flashing.
- D. Clean seam areas, overlap, and firmly roll sheet flashings into the adhesive. Hot-air weld side and end laps to ensure a watertight seam installation.
- E. Terminate and seal top of sheet flashings and mechanically anchor to substrate through termination bars.

3.8 FASCIA SYSTEM INSTALLATION

- A. Comply with manufacturer's written installation instructions. Anchor products securely to structural substrates to withstand lateral and thermal stresses and inward and outward loading pressures.
- B. Expansion Provisions: Install running lengths to allow controlled expansion for movement of metal components in relation not only to one another but also to adjoining dissimilar materials, including flashing and roofing membrane materials, in a manner sufficient to prevent water leakage, deformation, or damage.

3.9 FIELD QUALITY CONTROL

- A. Initial Roof Inspection: Arrange for roofing system manufacturer's technical personnel to inspect roofing installation on completion with Owner.
 - 1. Notify Architect or Owner 48 hours in advance of the date and time of inspection.
- B. Final Roof Inspection: Arrange for roofing system manufacturer's technical personnel to inspect roofing installation after initial roof inspection repairs are completed.
 - 1. Notify Architect or Owner 48 hours in advance of the date and time of inspection.
- C. Repair or remove and replace components of roofing system where inspections indicate that they do not comply with specified requirements.

3.10 PROTECTING AND CLEANING

- A. Protect roofing system from damage and wear during remainder of construction period. When remaining construction does not affect or endanger roofing, inspect roofing for deterioration and damage, describing its nature and extent in a written report, with copies to Architect and Owner.
- B. Correct deficiencies in or remove roofing system that does not comply with requirements, repair substrates, and repair or reinstall roofing system to a condition free of damage and deterioration at time of Substantial Completion and according to warranty requirements.
- C. Clean overspray and spillage from adjacent construction using cleaning agents and procedures recommended by manufacturer of affected construction.

3.11 ROOFING INSTALLER'S WARRANTY

- A. WHEREAS _____ of _____, herein called the "Roofing Installer," has performed roofing and associated work ("work") on the following project:
 - 1. Owner:
 - 2. Address:

3. Building Name/Type:
4. Address:
5. Area of Work:
6. Acceptance Date:
7. Warranty Period:
8. Expiration Date:

B. AND WHEREAS Roofing Installer has contracted (either directly with Owner or indirectly as a subcontractor) to warrant said work against leaks and faulty or defective materials and workmanship for designated Warranty Period,

C. NOW THEREFORE Roofing Installer hereby warrants, subject to terms and conditions herein set forth, that during Warranty Period Roofing Installer will, at Roofing Installer's own cost and expense, make or cause to be made such repairs to or replacements of said work as are necessary to correct faulty and defective work and as are necessary to maintain said work in a watertight condition.

D. This Warranty is made subject to the following terms and conditions:

1. Specifically excluded from this Warranty are damages to work and other parts of the building, and to building contents, caused by:
 - a. lightning;
 - b. peak gust wind speed exceeding ~~100~~ 90 mph;
 - c. fire;
 - d. activity on roofing by others, including construction contractors, maintenance personnel, other persons, and animals, whether authorized or unauthorized by Owner.
2. When work has been damaged by any of foregoing causes, Warranty shall be null and void until such damage has been repaired by Roofing Installer and until cost and expense thereof have been paid by Owner or by another responsible party so designated.
3. Roofing Installer is responsible for damage to work covered by this Warranty but is not liable for consequential damages to building or building contents resulting from leaks or faults or defects of work.
4. During Warranty Period, if Owner allows alteration of work by anyone other than Roofing Installer, including cutting, patching, and maintenance in connection with penetrations, attachment of other work, and positioning of anything on roof, this Warranty shall become null and void on date of said alterations, but only to the extent said alterations affect work covered by this Warranty. If Owner engages Roofing Installer to perform said alterations, Warranty shall not become null and void unless Roofing Installer, before starting said work, shall have notified Owner in writing, showing reasonable cause for claim, that said alterations would likely damage or deteriorate work, thereby reasonably justifying a limitation or termination of this Warranty.
5. During Warranty Period, if original use of roof is changed and it becomes used for, but was not originally specified for, a promenade, work deck, spray-cooled surface, flooded basin, or other use or service more severe than originally specified, this Warranty shall become null and void on date of said change, but only to the extent said change affects work covered by this Warranty.
6. Owner shall promptly notify Roofing Installer of observed, known, or suspected leaks, defects, or deterioration and shall afford reasonable opportunity for Roofing Installer to inspect work and to examine evidence of such leaks, defects, or deterioration.
7. This Warranty is recognized to be the only warranty of Roofing Installer on said work and shall not operate to restrict or cut off Owner from other remedies and resources lawfully available to Owner in cases of roofing failure. Specifically, this Warranty shall not operate to relieve Roofing Installer of responsibility for performance of original work according to requirements of the Contract Documents, regardless of whether Contract was a contract directly with Owner or a subcontract with Owner's General Contractor.

E. IN WITNESS THEREOF, this instrument has been duly executed this _____ day of _____, _____.

1. Authorized Signature: _____.
2. Name: _____.
3. Title: _____.

END OF SECTION 07 54 19

SECTION 09 64 66
WOOD ATHLETIC FLOORING

PART 1 - GENERAL

1.1 RELATED DOCUMENTS

- A. Drawings and general provisions of the Contract, including General and Supplementary Conditions and Division 01 Specification Sections, apply to this Section.

1.2 SUMMARY

- A. This Section includes wood athletic flooring.

1.3 COORDINATION

- A. Coordinate layout and installation of slab depressions to accommodate layout and height of wood athletic flooring assembly.
- B. Coordinate layout and installation of flooring with floor inserts for gymnasium equipment.

1.4 ACTION SUBMITTALS

- A. Product Data: For each type of product.
 - 1. Include construction details, material descriptions, dimensions of individual components and profiles, and finishes for wood athletic flooring.
- B. Shop Drawings: For each type of floor assembly, include the following:
 - 1. Plans, sections, and attachment details.
 - 2. Details of concrete-slab depressions.
 - 3. Expansion provisions and trim details.
 - 4. Layout, colors, widths, and dimensions of game lines and markers.
 - 5. Locations of floor inserts for athletic equipment installed through flooring assembly.
- C. Samples: For each exposed product and for each color and texture specified, approximately 12 inches long in size.
 - 1. Include Sample sets showing finishes and game-line and marker paints applied to wood flooring.
- D. Samples for Initial Selection: For each type of wood athletic flooring and accessory in each type of exposed color and finish.
 - 1. Include manufacturer's color charts showing colors and glosses available for the following:
 - a. Floor finishes.
 - b. Game-line and marker paints.

1.5 INFORMATIONAL SUBMITTALS

- A. Product Test Reports: For each wood athletic flooring system, for tests performed by a qualified testing agency.

1.6 CLOSEOUT SUBMITTALS

- A. Maintenance Data: For wood athletic flooring and finish systems to include in maintenance manuals.

1.7 QUALITY ASSURANCE

- A. Installer Qualifications: A firm or individual that has been approved by MFMA as an accredited Installer according to the MFMA Accreditation Program.
 - 1. Installer responsibilities include installation and field finishing of wood athletic flooring components and accessories, and application of game lines and markers.

1.8 DELIVERY, STORAGE, AND HANDLING

- A. Deliver floor assembly materials in unopened cartons or bundles.
- B. Protect wood from exposure to moisture. Do not deliver wood components until after concrete, masonry, plaster, ceramic tile, and similar wet-work is complete and dry.
- C. Store wood components in a dry, warm, well-ventilated, weathertight location and in a horizontal position.

1.9 FIELD CONDITIONS

- A. Conditioning period begins not less than seven days before wood athletic flooring installation, is continuous through installation, and continues not less than seven days after installation.
 - 1. Environmental Conditioning: Maintain ambient temperature between 65 and 75 deg F and relative humidity planned for building occupants, but not less than 35 percent or more than 50 percent, in spaces to receive wood athletic flooring during the conditioning period.
 - 2. Wood Conditioning: Move wood components into spaces where they will be installed, no later than beginning of the conditioning period.
 - a. Do not install wood athletic flooring until wood components adjust to relative humidity of, and are at same temperature as, spaces where they are to be installed.
 - b. Open sealed packages to allow wood components to acclimatize immediately on moving wood components into spaces in which they will be installed.
- B. After conditioning period, maintain relative humidity and ambient temperature planned for building occupants.
- C. Install wood athletic flooring after other finishing operations, including painting, have been completed.

PART 2 - PRODUCTS

2.1 MANUFACTURERS

- A. Basis-of-Design Manufacturer: Subject to compliance with requirements, provide Connor Sports Rezill Base RP-111 or approved products by one of the following:

- ~~1. Horner Sports Flooring.~~
2. Robbins Sports Surfaces – Eclipse SB Anchored
3. Aacer-Powerplay Edge
4. Action Floor Systems-Anchor Tech LP

2.2 SYSTEM DESCRIPTION

- A. System Type: Anchored resilient.
- B. Overall System Height: 1-5/8 inches

2.3 FLOORING MATERIALS

- A. Maple Flooring: Comply with MFMA grading rules for species, grade, and cut.
1. Certification: Provide flooring that carries MFMA mark on each bundle or piece.
- B. Random-Length Strip Flooring: Northern hard maple (*Acer saccharum*), kiln dried, random length, tongue and groove, and end matched.
1. Grade: MFMA-RL Second and Better.
 2. Cut: Flat.
 3. Thickness: 25/32 inch.
 4. Face Width: 2-1/4 inches.
 5. Flooring continues under telescoping stands/bleachers.

2.4 SUBFLOOR MATERIALS

- A. Plywood Underlayment: APA rated, C-D plugged, exterior glue, tongue and groove, Manufacturer's standard thickness.
- B. Resilient Pads: With air voids for resiliency and installed at manufacturer's standard spacing for product designation indicated above.
1. Material: Rubber.
 2. Thickness: 14 mm.

2.5 FINISHES

- A. Floor-Finish System: System of compatible components recommended in writing by flooring manufacturer, and MFMA approved.
1. Floor-Sealer Formulation: Pliable, penetrating type. MFMA Group 1, Sealers.
 2. Finish-Coat Formulation: Formulated for gloss finish indicated and multicoat application.
 - a. Type: MFMA Group 5, Water-Based Finishes.

3. Game-Line and Marker Paint: Industrial enamel compatible with finish coats and recommended in writing by manufacturers of finish coats, and paint for this use.
 - a. Game-Line Design:
 - 1) Provide the current NCAA men's and women's basketball, volleyball regulation game lines, and high school three point line on the main court.
 - 2) Provide side court lines of dissimilar color. Color and final markings to be determined in conference with Athletic Director. Provide color options.
 - 3) Provide oversized University of Maine at Presque Isle Athletics logo at center court. Striping at center logo to be limited visibility thin double lines so as not to interfere with logo image. Logo size to be up to 18' in height. Final size to be determined during shop drawing process. Contractor to provide meeting with floor striping designer and UMPI Athletic Director to review and finalize options.

2.6 ACCESSORIES

- A. Vapor Retarder: See specification SECTION 07 26 16 - BELOW-GRADE VAPOR RETARDERS.
- B. Resilient Wall Base: Molded, vented, rubber or vinyl cove base; 4 by 3 by 48 inches; with premolded outside corners.
 1. Color: Black.
- C. Thresholds: As specified in Section 08 71 00 "Door Hardware."
- D. Fasteners: Type and size recommended by manufacturer, but not less than those recommended by MFMA for application indicated.
- E. Trowelable Leveling and Patching Compound: Latex-modified, hydraulic-cement-based formulation approved by wood athletic flooring manufacturer.

PART 3 - EXECUTION

3.1 EXAMINATION

- A. Examine substrates, areas, and conditions, with Installer present, for compliance with requirements for maximum moisture content, installation tolerances, and other conditions affecting performance of the Work.
- B. Proceed with installation only after unsatisfactory conditions have been corrected.
- C. Concrete Slabs: Verify that concrete substrates are dry and moisture-vapor emissions are within acceptable levels according to manufacturer's written instructions.
 1. Moisture Testing: Perform tests so that each test area does not exceed 1000 sq. ft., and perform no fewer than three tests in each installation area and with test areas evenly spaced in installation areas.
 - a. Relative Humidity Test: Using in situ probes, ASTM F2170. Proceed with installation only after substrates have a maximum 85 percent relative humidity level measurement.
 - b. Perform additional moisture tests recommended by manufacturer. Proceed with installation only after substrates pass testing.

3.2 PREPARATION

A. Concrete Slabs:

1. Grind high spots and fill low spots on concrete substrates to produce a maximum 1/8-inch deviation in any direction when checked with a 10-foot straight edge.
2. Use trowelable leveling and patching compounds, according to manufacturer's written instructions, to fill cracks, holes, and depressions in substrates.

B. Broom and vacuum clean substrates to be covered immediately before product installation. After cleaning, examine substrates for moisture, alkaline salts, carbonation, or dust. Proceed with installation only after unsatisfactory conditions have been corrected.

3.3 INSTALLATION

A. Comply with wood athletic flooring manufacturer's written instructions, but not less than written recommendations of MFMA applicable to flooring type indicated.

B. Pattern: Lay flooring parallel with long dimension of space to be floored unless otherwise indicated.

C. Expansion Spaces: Provide as indicated, but not less than that required by manufacturer's written instructions and MFMA's written recommendations at walls and other obstructions, and at interruptions and terminations of flooring.

1. Cover expansion spaces with base molding, trim, and saddles, as indicated on Drawings.

D. Vapor Retarder: Cover entire slab area beneath wood flooring. Install with joints lapped a minimum of 6 inches and sealed.

E. Underlayment: Install perpendicular to direction of flooring, staggering end joints in adjacent rows.

F. Strip Flooring: Mechanically fasten perpendicular to supports.

G. Installation Tolerances: 1/8 inch in 10 feet of variance from level.

3.4 SANDING AND FINISHING

A. Allow installed flooring to acclimate to ambient conditions before sanding.

B. Follow applicable recommendations in MFMA's "Industry Recommendations for Sanding, Sealing, Court Lining, Finishing, and Resurfacing of Maple Gym Floors."

C. Machine sand with coarse, medium, and fine grades of sandpaper to achieve a level, smooth, uniform surface without ridges or cups. Remove sanding dust by tack or vacuum.

D. Finish: Apply seal and finish coats of finish system according to finish manufacturer's written instructions. Provide no fewer than four coats total and no fewer than two finish coats.

1. Water-Based Finishes: Use finishing methods recommended by finish manufacturer to reduce grain raise and sidebonding effect.
2. Game-Line and Marker Paint: Apply game-line and marker paint between final seal coat and first finish coat according to paint manufacturer's written instructions.
 - a. Mask flooring at game lines and markers, and apply paint to produce lines and markers with sharp edges.
 - b. Where game lines cross, break minor game line at intersection; do not overlap lines.

- c. Apply game lines and markers in widths and colors according to NCAA regulations.
- d. Apply finish coats after game-line and marker paint is fully cured.

3.5 PROTECTION

- A. Protect wood athletic flooring during remainder of construction period to allow finish to cure and to ensure that flooring and finish are without damage or deterioration at time of Substantial Completion.
 - 1. Do not cover flooring after finishing until finish reaches full cure and not before seven days after applying last finish coat.
 - 2. Do not move heavy and sharp objects directly over flooring. Protect fully cured floor finishes and surfaces with plywood or hardboard panels to prevent damage from storing or moving objects over flooring.

END OF SECTION 09 64 66

SECTION 09 68 13
TILE CARPETING

PART 1 - GENERAL

1.1 RELATED DOCUMENTS

- A. Drawings and general provisions of the Contract, including General and Supplementary Conditions and Division 01 Specification Sections, apply to this Section.

1.2 SUMMARY

- A. Section includes modular carpet tile.
- B. Related Requirements:
1. Section 024119 "Selective Demolition" for removing existing floor coverings.
 2. Section 096516 "Resilient Sheet Flooring" for resilient wall base and accessories installed with carpet tile.

1.3 PREINSTALLATION MEETINGS

- A. Preinstallation Conference: Conduct conference at Project site.
1. Review methods and procedures related to carpet tile installation including, but not limited to, the following:
 - a. Review delivery, storage, and handling procedures.
 - b. Review ambient conditions and ventilation procedures.
 - c. Review subfloor preparation procedures.

1.4 ACTION SUBMITTALS

- A. Shop Drawings: For carpet tile installation, plans showing the following:
1. Columns, doorways, enclosing walls or partitions, built-in cabinets, and locations where cutouts are required in carpet tiles.
 2. Carpet tile type, color, and dye lot.
 3. Type of subfloor.
 4. Type of installation.
 5. Pattern of installation.
 6. Pattern type, location, and direction.
 7. Pile direction.
 8. Type, color, and location of insets and borders.
 9. Type, color, and location of edge, transition, and other accessory strips.
 10. Transition details to other flooring materials.
- B. Samples for Verification: For each of the following products and for each color and texture required. Label each Sample with manufacturer's name, material description, color, pattern, and designation indicated on Drawings and in schedules.
1. Carpet Tile: Full-size Sample.

- C. Product Schedule: For carpet tile. Use same designations indicated on Drawings.

1.5 INFORMATIONAL SUBMITTALS

- A. Qualification Data: For Installer.
- B. Product Test Reports: For carpet tile, for tests performed by a qualified testing agency.
- C. Sample Warranty: For special warranty.

1.6 CLOSEOUT SUBMITTALS

- A. Maintenance Data: For carpet tiles to include in maintenance manuals. Include the following:
 - 1. Methods for maintaining carpet tile, including cleaning and stain-removal products and procedures and manufacturer's recommended maintenance schedule.
 - 2. Precautions for cleaning materials and methods that could be detrimental to carpet tile.

1.7 MAINTENANCE MATERIAL SUBMITTALS

- A. Furnish extra materials, from the same product run, that match products installed and that are packaged with protective covering for storage and identified with labels describing contents.
 - 1. Carpet Tile: Full-size units equal to 5 percent of amount installed for each type indicated, but not less than 10 sq. yd. (8.3 sq. m).

1.8 QUALITY ASSURANCE

- A. Installer Qualifications: An experienced installer who is certified by the International Certified Floorcovering Installers Association at a minimum Commercial II certification level.

1.9 DELIVERY, STORAGE, AND HANDLING

- A. Comply with CRI's "CRI Carpet Installation Standard."

1.10 FIELD CONDITIONS

- A. Comply with CRI's "CRI Carpet Installation Standard" for temperature, humidity, and ventilation limitations.
- B. Environmental Limitations: Do not deliver or install carpet tiles until spaces are enclosed and weathertight, wet-work in spaces is complete and dry, and ambient temperature and humidity conditions are maintained at levels planned for building occupants during the remainder of the construction period.
- C. Do not install carpet tiles over concrete slabs until slabs have cured and are sufficiently dry to bond with adhesive and concrete slabs have pH range recommended by carpet tile manufacturer.
- D. Where demountable partitions or other items are indicated for installation on top of carpet tiles, install carpet tiles before installing these items.

1.11 WARRANTY

- A. Special Warranty for Carpet Tiles: Manufacturer agrees to repair or replace components of carpet tile installation that fail in materials or workmanship within specified warranty period.
 - 1. Warranty does not include deterioration or failure of carpet tile due to unusual traffic, failure of substrate, vandalism, or abuse.
 - 2. Failures include, but are not limited to, the following:
 - a. More than 10 percent edge raveling, snags, and runs.
 - b. Dimensional instability.
 - c. Excess static discharge.
 - d. Loss of tuft-bind strength.
 - e. Loss of face fiber.
 - f. Delamination.
 - 3. Warranty Period: Lifetime commercial limited (CPT1)

PART 2 - PRODUCTS

2.1 CARPET TILE – CPT1

- A. Basis of Design: As indicated in Finish Legend of drawings.
- B. Fiber Content: Ecosolution Q Nylon
- C. Dye Method: 100% Solution Dyed
- D. Pile Characteristic: Multi-level cut/loop
- E. Density: 6372 oz/yd²
- F. Pile Thickness: 0.113 in
- G. Stitches: 8.5 per in
- H. Tufted Weight: 20 oz/ yd²
- I. Primary and Secondary Backing: Synthetic/Ecoworx
- J. Applied Treatments:
 - 1. Soil-Resistance Treatment: Manufacturer's standard treatment
- K. Performance Characteristics:
 - 1. Pill test: pass
 - 2. Radiant Panel: Class 1
 - 3. NBS Some: less than 450
 - 4. Electrostatic Propensity: Less than 3.5 kV according to AATCC 134.

2.2 INSTALLATION ACCESSORIES

- A. Trowelable Leveling and Patching Compounds: Latex-modified, hydraulic-cement-based formulation provided or recommended by carpet tile manufacturer.

- B. Adhesives: Water-resistant, mildew-resistant, nonstaining, pressure-sensitive type to suit products and subfloor conditions indicated, that comply with flammability requirements for installed carpet tile, and are recommended by carpet tile manufacturer for releasable installation.
 - 1. LokDots (CPT1)
- C. Metal Edge/Transition Strips: Refer to ceramic tiling and resilient tile specifications.

PART 3 - EXECUTION

3.1 EXAMINATION

- A. Examine substrates, areas, and conditions, with Installer present, for compliance with requirements for maximum moisture content, alkalinity range, installation tolerances, and other conditions affecting carpet tile performance.
- B. Examine carpet tile for type, color, pattern, and potential defects.
- C. Concrete Slabs: Verify that finishes comply with requirements specified in Section 033000 "Cast-in-Place Concrete" and that surfaces are free of cracks, ridges, depressions, scale, and foreign deposits.
 - 1. Moisture Testing: Perform tests per manufacturer's instructions.
- D. Proceed with installation only after unsatisfactory conditions have been corrected.

3.2 PREPARATION

- A. General: Comply with CRI's "Carpet Installation Standards" and with carpet tile manufacturer's written installation instructions for preparing substrates indicated to receive carpet tile.
- B. Use trowelable leveling and patching compounds, according to manufacturer's written instructions, to fill cracks, holes, depressions, and protrusions in substrates. Fill or level cracks, holes and depressions 1/8 inch (3 mm) wide or wider, and protrusions more than 1/32 inch (0.8 mm) unless more stringent requirements are required by manufacturer's written instructions.
- C. Concrete Substrates: Remove coatings, including curing compounds, and other substances that are incompatible with adhesives and that contain soap, wax, oil, or silicone, without using solvents. Use mechanical methods recommended in writing by adhesive and carpet tile manufacturers.
- D. Metal Substrates: Clean grease, oil, soil and rust, and prime if recommended in writing by adhesive manufacturer. Rough sand painted metal surfaces and remove loose paint. Sand aluminum surfaces, to remove metal oxides, immediately before applying adhesive.
- E. Broom and vacuum clean substrates to be covered immediately before installing carpet tile.

3.3 INSTALLATION

- A. General: Comply with CRI's "CRI Carpet Installation Standard," Section 18, "Modular Carpet" and with carpet tile manufacturer's written installation instructions.
- B. Installation Method: As recommended in writing by carpet tile manufacturer, with releasable, pressure-sensitive adhesive.
- C. Maintain dye-lot integrity. Do not mix dye lots in same area.

- D. Cut and fit carpet tile to butt tightly to vertical surfaces, permanent fixtures, and built-in furniture including cabinets, pipes, outlets, edgings, and thresholds. Bind or seal cut edges as recommended by carpet tile manufacturer.
- E. Extend carpet tile into toe spaces, door reveals, closets, open-bottomed obstructions, removable flanges, alcoves, and similar openings.
- F. Maintain reference markers, holes, and openings that are in place or marked for future cutting by repeating on carpet tile as marked on subfloor. Use nonpermanent, nonstaining marking device.
- G. Install pattern parallel to walls and borders.
- H. Access Flooring: Stagger joints of carpet tiles so carpet tile grid is offset from access flooring panel grid. Do not fill seams of access flooring panels with carpet adhesive; keep seams free of adhesive.

3.4 CLEANING AND PROTECTION

- A. Perform the following operations immediately after installing carpet tile:
 - 1. Remove yarns that protrude from carpet tile surface.
 - 2. Vacuum carpet tile using commercial machine with face-beater element.
- B. Protect installed carpet tile to comply with CRI's "Carpet Installation Standard," Section 20, "Protecting Indoor Installations."
- C. Protect carpet tile against damage from construction operations and placement of equipment and fixtures during the remainder of construction period. Use protection methods indicated or recommended in writing by carpet tile manufacturer.

END OF SECTION 09 68 13

SECTION 09 91 20
PAINTING

PART 1 - GENERAL

1.1 RELATED DOCUMENTS

- A. Drawings and general provisions of the Contract Documents, including General and Supplementary General Conditions and Division 1 Specification Sections, apply to this Section.

1.2 SUMMARY

- A. This Section includes surface preparation and the application of paint systems on the following exterior and interior substrates:

1. Steel- including ductwork and piping.
2. Cast iron drainage grates and frames.
3. Wood.
4. Plywood.
5. Gypsum board.
6. Concrete including floor sealer.
7. Concrete masonry units.

- B. Specific Items Not Requiring Painting are as Follows:

1. Pre-finished wood doors and architectural woodwork and paneling.
2. Ceramic tile.
3. Acoustical ceiling panels and suspension grid.
4. Anodized aluminum windows and door frames.
5. Metal wall panels.
6. Gypsum drywall surfaces above finished ceilings.
7. Shop finished wood casework.
8. Plastic laminate.
9. Unless otherwise indicated, shop priming of ferrous metal items and fabricated components are included under their respective trades.
10. Exposed ceilings, unless noted otherwise in finish schedule.

- C. Related Sections include the following:

1. Division 4 Section "Unit Masonry".
2. Division 5 Sections for shop priming of metal substrates with primers specified in this Section.
3. Division 6 Section "Rough Carpentry" for plywood backer panels.
4. Division 6 Sections for "Interior Architectural Woodwork" and "Flush Wood Paneling".
5. Division 8 "Hollow Metal Doors and Frames".
6. Division 8 "Sectional Doors".

1.3 SUBMITTALS

- A. Product Data: For each type of product indicated for color and sheen accuracy.

1.4 DELIVERY, STORAGE, AND HANDLING

- A. Store materials not in use in tightly covered containers in well-ventilated areas with ambient temperatures continuously maintained at not less than 45 deg F.

1. Maintain containers in clean condition, free of foreign materials and residue.
2. Remove rags and waste from storage areas daily.

1.5 PROJECT CONDITIONS

- A. Apply paints *only* when temperature of surfaces to be painted and ambient air temperatures are between 50 and ~~95~~ 80 deg F.
- B. Do not apply paints in snow, rain, fog, or mist; when relative humidity exceeds ~~85~~ 50 percent; at temperatures less than 5 deg F above the dew point; or to damp or wet surfaces.

PART 2 - PRODUCTS

2.1 MANUFACTURERS

- A. **Basis of Design** Manufacturers: Subject to compliance with requirements, available manufacturers offering products that may be incorporated into the Work include, but are not limited to, the following

1. ~~I.C.I.~~
2. ~~Benjamin Moore.~~
3. Sherwin Williams. (*PT-3, PT-4, PT-5*)
4. ~~Dulux.~~
5. ~~DeVoe.~~
6. ~~M.A.B.~~
7. ~~Duron.~~
8. ~~PPG.~~
9. ~~Porter.~~
10. ~~Glidden.~~
11. ~~Pratt and Lambert.~~
12. Tnemec.
13. **ICP Scuffmaster** (*PT1, PT-2*)

2.2 PAINT, GENERAL

- A. Material Compatibility:

1. Provide materials for use within each paint system that are compatible with one another and substrates indicated, under conditions of service and application as demonstrated by manufacturer, based on testing and field experience.
2. Basis of Design: Interior paint products as indicated in the Finish Legend in Drawings.
3. For each coat in a paint system, provide products recommended in writing by manufacturers of topcoat for use in paint system and on substrate indicated.
 - a. Flat Paints and Coatings: 50 g/L.
 - b. Nonflat Paints and Coatings: 150 g/L.
 - c. Dry-Fog Coatings: 400 g/L.
 - d. Primers, Sealers, and Undercoaters: 200 g/L.
 - e. Anticorrosive and Antirust Paints Applied to Ferrous Metals: 250 g/L.
 - f. Zinc-Rich Industrial Maintenance Primers: 340 g/L.
 - g. Pretreatment Wash Primers: 420 g/L.
 - h. Floor Coatings: 100 g/L
 - i. Shellacs, Clear: 730 g/L.
 - j. Shellacs, Pigmented: 550 g/L.

- B. Low-Emitting Materials: Interior paints and coatings shall comply with the testing and

product requirements of the California Department of Health Services' "Standard Practice for the Testing of Volatile Organic Emissions from Various Sources Using Small-Scale Environmental Chambers."

C. Colors:

1. Refer to Finish Legend in drawings.

2.3 PAINTING PRODUCTS AND SCHEDULE

A. Steel Substrates – Exterior/Interior:

1. Shop Primer: Synthetic rust-inhibiting primer.
2. First and Second Coats: Alkyd semi-gloss enamel.

B. Concrete Floor Sealer - Interior:

1. Prime Coat: TNEMEC Series 287 Enviro-Tread.
2. Finish Coat: Same as primer.

C. Wood – Interior:

1. Primer: Enamel undercoat.
2. First and Second Coats: Alkyd enamel, odorless (semi-gloss).

D. Gypsum Board and Concrete – Interior:

1. Primer: Latex based interior primer. (PT-3, PT-4, PT-5)
2. First and Second Coats: Latex based eggshell enamel (PT-3, PT-4, PT-5)
3. Water-based polyurethane/acrylic pearlescent paint finish system: primer, base coat, effect coat, *satin clear coat. (PT1, PT-2).*

E. Concrete Masonry – Interior:

1. Primer/Filler: Latex based interior primer filler.
2. First and Second Coats: Latex based eggshell enamel. (PT-3, PT-4, PT-5)
3. Water-based polyurethane/acrylic pearlescent paint finish system: primer, base coat, effect coat, *satin clear coat. (PT1, PT-2).*

PART 3 - EXECUTION

3.1 EXAMINATION

- A. Examine substrates and conditions, with Applicator present, for compliance with requirements for maximum moisture content and other conditions affecting performance of work.
- B. Maximum Moisture Content of Substrates: When measured with an electronic moisture meter as follows:
1. Concrete: 12 percent.
 2. Wood: 15 percent.
 3. Gypsum Board: 12 percent.

- C. Verify suitability of substrates, including surface conditions and compatibility with existing finishes and primers.
- D. Begin coating application only after unsatisfactory conditions have been corrected and surfaces are dry.
 - 1. Beginning coating application constitutes Contractor's acceptance of substrates and conditions.

3.2 PREPARATION

- A. Comply with manufacturer's written instructions and recommendations in "MPI Architectural Painting Specification Manual" applicable to substrates and paint systems indicated.
- B. Remove plates, machined surfaces, and similar items already in place that are not to be painted. If removal is impractical or impossible because of size or weight of item, provide surface-applied protection before surface preparation and painting.
 - 1. After completing painting operations, use workers skilled in the trades involved to reinstall items that were removed. Remove surface-applied protection if any.
 - 2. Do not paint over labels of independent testing agencies or equipment name, identification, performance rating, or nomenclature plates.
- C. Clean substrates of substances that could impair bond of paints, including dirt, oil, grease, and incompatible paints and encapsulants.
 - 1. Remove incompatible primers and reprime substrate with compatible primers as required to produce paint systems indicated.
- D. Steel Substrates: Remove rust and loose mill scale. Clean using methods recommended in writing by paint manufacturer.
- E. Concrete Substrates: Remove release agents, curing compounds, efflorescence, and chalk. Do not paint surfaces if moisture content or alkalinity of surfaces to be painted exceeds that permitted in manufacturer's written instructions.
 - 1. Concrete Floors: Prepare by light shot-blast, mechanical abrasion or acid etching to remove laitance, curing compounds, sealers, and other contaminants and to provide surface profile in accordance with ASTM D 4259, ICRI CSP 1-3.
- F. Wood Substrates:
 - 1. Scrape and clean knots and apply coat of knot sealer before applying primer.
 - 2. Sand surfaces that will be exposed to view, and dust off.
 - 3. Prime edges, ends, faces, undersides, and back sides of wood.
 - 4. After priming, fill holes and imperfections in the finish surfaces with putty or plastic woodfiller. Sand smooth when dried.

3.3 APPLICATION

- A. Apply paints according to manufacturer's written instructions.
 - 1. Use applicators and techniques suited for paint and substrate indicated.
 - 2. Paint surfaces behind movable items same as similar exposed surfaces. Before final installation, paint surfaces behind permanently fixed items with prime coat only.
- B. Tint each undercoat a lighter shade to facilitate identification of each coat if multiple coats of same material are to be applied. Tint undercoats to match color of topcoat, but provide sufficient

difference in shade of undercoats to distinguish each separate coat.

- C. If undercoats or other conditions show through topcoat, apply additional coats until cured film has a uniform paint finish, color, and appearance.
- D. Apply paints to produce surface films without cloudiness, spotting, holidays, laps, brush marks, roller tracking, runs, sags, ropiness, or other surface imperfections. Cut in sharp lines and color breaks.

3.4 CLEANING AND PROTECTION

- A. At end of each workday, remove rubbish, empty cans, rags, and other discarded materials from Project site.
- B. After completing paint application, clean spattered surfaces. Remove spattered paints by washing, scraping, or other methods. Do not scratch or damage adjacent finished surfaces.
- C. Protect work of other trades against damage from paint application. Correct damage to work of other trades by cleaning, repairing, replacing, and refinishing, as approved by Architect, and leave in an undamaged condition.
- D. At completion of construction activities of other trades, touch up and restore damaged or defaced painted surfaces.

END OF SECTION 09 91 20

SECTION 23 51 13.16
VENT DAMPERS

PART 1 - GENERAL

1.1 RELATED DOCUMENTS

- A. Drawings and general provisions of the Contract, including General and Supplementary Conditions and Division 01 Specification Sections, apply to this Section.

1.2 SUMMARY

- A. Section Includes:

- 1. Barometric dampers.

- B. Related Requirements:

- 1. Section 235133 "Insulated Sectional Chimneys" for listed chimney liners; listed building-heating-appliance chimneys; listed, refractory-lined metal chimneys; and field-fabricated chimneys.

1.3 ACTION SUBMITTALS

- A. Product Data: For each type of product.

- B. Shop Drawings: For each type of product.

- 1. Include plans, elevations, sections, and attachment details.
 - 2. Include details of equipment assemblies. Indicate dimensions, weights, loads, required clearances, method of field assembly, components, and location and size of each field connection.

1.4 CLOSEOUT SUBMITTALS

- A. Operation and Maintenance Data: For draft control devices to include in emergency, operation, and maintenance manuals.

PART 2 - PRODUCTS

2.1 BAROMETRIC DAMPERS

- A. Manufacturers: Subject to compliance with requirements, available manufacturers offering products that may be incorporated into the Work include, but are not limited to the following:

- 1. ENERVEX Inc.
 - 2. Field Controls L.L.C.
 - 3. Tjernlund Products, Inc.

- B. Damper Construction: High-temperature-enamel-painted steel damper and housing with galvanized-steel breeching connection. Adjustable counterweight with lock. Include knife-edge bearings that do not require lubrication.
- C. Size: Matching breeching size indicated on the Drawings.

PART 3 - EXECUTION

3.1 INSTALLATION

- A. Install listed components in a manner complying with the listing.
- B. Secure barometric dampers to breechings with hardware compatible with connected materials.
- C. Locate barometric dampers as close to draft hood collar as possible.
- D. Secure barometric dampers to appliances, breechings, or chimneys with hardware compatible with connected materials.

END OF SECTION 23 51 13.16

SECTION 23 51 33
INSULATED SECTIONAL CHIMNEYS

PART 1 - GENERAL

1.1 RELATED DOCUMENTS

- A. Drawings and general provisions of the Contract, including General and Supplementary Conditions and Division 01 Specification Sections, apply to this Section.

1.2 SUMMARY

- A. Section Includes:

- 1. Listed building-heating-appliance chimneys.

- B. Related Requirements:

- 1. Section 235113.16 "Vent Dampers" for motorized and barometric dampers.

1.3 ACTION SUBMITTALS

- A. Product Data: For each type of product.

- 1. Include construction details, material descriptions, dimensions of individual components and profiles, and finishes for product.

- B. Shop Drawings: For chimneys and stacks.

- 1. Include plans, elevations, sections, and attachment details.
 - 2. Include details of equipment assemblies. Indicate dimensions, weights, loads, required clearances, method of field assembly, components, and location and size of each field connection.
 - 3. Detail fabrication and assembly of hangers and seismic restraints.

1.4 INFORMATIONAL SUBMITTALS

- A. Welding certificates.

- B. Sample Warranty: For special warranty.

1.5 QUALITY ASSURANCE

- A. Welding Qualifications: Qualify procedures and personnel according to the following:

- 1. AWS D1.1/D1.1M, "Structural Welding Code - Steel," for hangers and supports.
 - 2. AWS D9.1/D9.1M, "Sheet Metal Welding Code," for shop and field welding of joints and seams in stacks.

- B. Certified Sizing Calculations: Manufacturer shall certify venting system sizing calculations.

1.6 WARRANTY

- A. Special Warranty: Manufacturer agrees to repair or replace components of venting system that fail in materials or workmanship within specified warranty period.
 - 1. Failures include, but are not limited to, structural failures caused by expansion and contraction.
 - 2. Warranty Period: 10 years from date of Substantial Completion.

PART 2 - PRODUCTS

2.1 LISTED BUILDING-HEATING-APPLIANCE CHIMNEYS

- A. Manufacturers: Subject to compliance with requirements, available manufacturers offering products that may be incorporated into the Work include, but are not limited to the following:
 - 1. American Metal Products.
 - 2. Hart & Cooley, LLC.
 - 3. Heatfab Saf-T Vent.
 - 4. M&G DuraVent, Inc.; a member of the M&G Group.
 - 5. Metal-Fab, Inc.
 - 6. Selkirk Corporation.
- B. Description: Double-wall metal vents tested according to UL 103 and UL 959 and rated for 1400 deg F continuously or 1800 deg F for 10 minutes; with positive or negative flue pressure complying with NFPA 211.
- C. Construction: Inner shell and outer jacket separated by at least a 1-inch annular space filled with high-temperature, ceramic-fiber insulation.
- D. Inner Shell: ASTM A666, Type 304 stainless steel.
- E. Outer Jacket: Galvanized or stainless steel.
- F. Accessories: Tees, elbows, increasers, draft-hood connectors, terminations, adjustable roof flashings, storm collars, support assemblies, thimbles, firestop spacers, and fasteners; fabricated from similar materials and designs as vent-pipe straight sections; all listed for same assembly.

PART 3 - EXECUTION

3.1 EXAMINATION

- A. Examine areas and conditions for compliance with requirements for installation tolerances and other conditions affecting performance of Work.
- B. Proceed with installation only after unsatisfactory conditions have been corrected.

3.2 APPLICATION

- A. Listed Building-Heating-Appliance Chimneys: Boilers, oven vents, water heaters, exhaust for engines, fireplaces, and other solid-fuel-burning appliances.

3.3 INSTALLATION OF LISTED CHIMNEYS

- A. Coordinate size and location of concrete bases. Cast anchor-bolt inserts into bases. Comply with requirements in Section 033000 "Cast-in-Place Concrete" for concrete, reinforcement, and formwork.
- B. Comply with minimum clearances from combustibles and minimum termination heights according to product listing or NFPA 211, whichever is most stringent.
- C. Seal between sections of positive-pressure vents according to manufacturer's written installation instructions, using sealants recommended by manufacturer.
- D. Lap joints in direction of flow.
- E. Connect base section to foundation using anchor lugs of size and number recommended by manufacturer.
- F. Join sections with acid-resistant joint cement to provide continuous joint and smooth interior finish.
- G. Erect stacks plumb to finished tolerance of no more than 1 inch out of plumb from top to bottom.

3.4 CLEANING

- A. After completing system installation, including outlet fittings and devices, inspect exposed finish. Remove burrs, dirt, and construction debris, and repair damaged finishes.
- B. Provide temporary closures at ends of chimneys and stacks that are not completed or connected to equipment.

END OF SECTION 23 51 33

SECTION 23 52 23
CAST-IRON BOILERS

PART 1 - GENERAL

1.1 RELATED DOCUMENTS

- A. Drawings and general provisions of the Contract, including General and Supplementary Conditions and Division 01 Specification Sections, apply to this Section.

1.2 SUMMARY

- A. Section includes cast-iron boilers, trim, and accessories for generating steam.

1.3 ACTION SUBMITTALS

- A. Product Data: For each type of product.
 - 1. Include construction details, material descriptions, dimensions of individual components and profiles, and finishes for boilers.
 - 2. Include rated capacities, operating characteristics, and furnished specialties and accessories.
- B. Shop Drawings: For boilers, boiler trim, and accessories.
 - 1. Include plans, elevations, sections, and attachment details.
 - 2. Include details of equipment assemblies. Indicate dimensions, weights, loads, required clearances, method of field assembly, components, and location and size of each field connection.
 - 3. Include diagrams for power, signal, and control wiring.

1.4 INFORMATIONAL SUBMITTALS

- A. Source quality-control reports.
- B. Field quality-control reports.
- C. Sample Warranty: For special warranty.
- D. Product Test Reports:
 - 1. CSA B51 pressure vessel Canadian Registration Number (CRN).
 - 2. Startup service reports.

1.5 CLOSEOUT SUBMITTALS

- A. Operation and Maintenance Data: For boilers, components, and accessories to include in emergency, operation, and maintenance manuals.

1.6 WARRANTY

- A. Manufacturer's Warranty: Manufacturer agrees to repair or replace controls and sections of boilers that fail in materials or workmanship within specified warranty period.
 - 1. Warranty Period for Controls: Two years from date of Substantial Completion.
 - 2. Warranty Period for Boiler Sections: Ten years from date of Substantial Completion.

PART 2 - PRODUCTS

2.1 PERFORMANCE REQUIREMENTS

- A. Electrical Components, Devices, and Accessories: Listed and labeled as defined in NFPA 70, by a qualified testing agency, and marked for intended location and application.
- B. ASME Compliance: Fabricate and label boilers to comply with 2010 ASME Boiler and Pressure Vessel Code.
- C. ASHRAE/IES 90.1 Compliance: Boilers shall have minimum efficiency according to "Gas and Oil Fired Boilers - Minimum Efficiency Requirements."
- D. DOE Compliance: Minimum efficiency shall comply with 10 CFR 430, Subpart B, Appendix N.
- E. I=B=R Compliance: Boilers shall be tested and rated according to AHRI's "Rating Procedure for Heating Boilers" and "Testing Standard for Commercial Boilers," with I=B=R emblem on a nameplate affixed to boiler.
- F. Mounting Frame: Steel rails used to mount assembled boiler package on concrete base.

2.2 MANUFACTURERS

- A. Manufacturers: Subject to compliance with requirements, provide products by the following:
 - 1. Weil McLain (only per Owner's project requirements)

2.3 MANUFACTURED UNITS

- A. Description: Factory fabricated and field assembled.
 - 1. Cast-iron sections shall be sealed pressure tight and held together with individual tie rods, including insulated jacket and flue-gas vent connection.
 - 2. Ship cast-iron sections disassembled with all materials and equipment, including seals, tie rods, and insulated jacket and flue-gas vent connection for field assembly.
- B. Cast-Iron Section Design:
 - 1. Configuration: Wet base.
 - 2. Number of Passes: Multiple.
 - 3. Sectional Joints: High-temperature sealant to seal flue-gas passages not in contact with heating medium, elastomer O-ring gaskets at steam/water passages, fiber roping, and held together with tie rods.
 - 4. Drain and blowdown tappings.
 - 5. Return injection tube to equalize water flow to all sections.
 - 6. Crown inspection tappings with brass plugs.

7. Built-in air separator.
- C. Combustion Chamber: Equipped with refractory liner and flame observation ports, front and back.
- D. Casing:
1. Jacket: Galvanized sheet metal, with snap-in or interlocking closures and baked-enamel protective finish.
 2. Insulation: Minimum 3-inch-thick, mineral-fiber insulation surrounding the heat exchanger.
 3. Combustion Chamber Access: Refractory lined, hinged, front.
 4. Access: For cleaning between cast-iron sections.
 5. Draft Hood: Flue canopy and rear cast-iron flue connection with adjustable outlet damper assembly.
 6. Control Cabinet: Sheet metal casing shall cover all controls, gas train, and burner.

2.4 OIL BURNER

- A. Burner: Welded construction with multivane, stainless-steel, flame-retention diffuser for fuel oil.
- B. Blower: Forward-curved centrifugal fan integral to burner, directly driven by motor, with adjustable, dual-blade damper assembly and locking quadrant to set air-fuel ratio.
1. Motors: Comply with NEMA designation, temperature rating, service factor, and efficiency requirements for motors specified in Section 230513 "Common Motor Requirements for HVAC Equipment."
 - a. Motor Sizes: Minimum size as indicated; if not indicated, large enough so driven load will not require motor to operate in service factor range above 1.0.
- C. Oil Supply: Control devices and low-high-low control sequence shall comply with requirements in ANSI/UL 296.
1. Oil Pump: Two-stage, gear-type oil pump integral to and directly driven by blower shall be capable of producing 300-psig discharge pressure and 15-inch Hg vacuum.
 2. Oil Piping Specialties:
 - a. Suction-line, manual gate valve.
 - b. Removable-mesh oil strainer.
 - c. 0- to 30-inch Hg vacuum; 0- to 30-psig vacuum-pressure gage.
 - d. 0- to 300-psig oil-nozzle pressure gage.
 - e. Nozzle-line, solenoid-safety-shutoff oil valve.
- D. Pilot: Intermittent-electric-spark pilot ignition with 100 percent main-valve and pilot-safety shutoff solenoid using cadmium sulfide or UV scanner flame-safety control.

2.5 TRIM FOR STEAM BOILERS

- A. Include devices sized to comply with ASME B31.9.
- B. Pressure Controllers: Operating, firing rate, and high limit.
- C. Safety Relief Valve:
1. Size and Capacity: As required for equipment according to 2010 ASME Boiler and Pressure Vessel Code.

2. Description: Fully enclosed steel spring with adjustable pressure range and positive shutoff; factory set and sealed.
 - a. Drip-Pan Elbow: Cast iron and having threaded inlet and outlet with threads complying with ASME B1.20.1.
- D. Pressure Gage: Minimum 3-1/2-inch diameter. Gage shall have normal operating pressure about 50 percent of full range.
- E. Water Column: Minimum 12-inch glass gage with shutoff cocks.
- F. Drain Valves: Minimum NPS 3/4 or nozzle size with hose-end connection.
- G. Blowdown Valves: Factory-installed bottom and surface, slow-acting blowdown valves same size as boiler nozzle.
- H. Stop Valves: Boiler inlets and outlets, except safety relief valves or preheater inlet and outlet, shall be equipped with stop valve in an accessible location as near as practical to boiler nozzle and same size as or larger than nozzle. Valves larger than NPS 2 shall have rising stem.
- I. Stop-Check Valves: Factory-installed, stop-check valve and stop valve at boiler outlet with free-blow drain valve factory installed between the two valves and visible when operating stop-check valve.

2.6 CONTROLS

- A. Refer to Section 230900 "Instrumentation and Controls for HVAC" and Section 230993 "Sequence of Operations for HVAC"
- B. Boiler operating controls shall include the following devices and features:
 1. Control transformer.
 2. Set-Point Adjust: Set points shall be adjustable.
 3. Operating Pressure Control: Factory wired and mounted to cycle burner.
 4. Low-Water Cutoff and Pump Control: Cycle feedwater pump(s) for makeup water control.
- C. Safety Controls: To maintain safe operating conditions, burner safety controls limit burner operation.
 1. High Cutoff: Automatic reset stops burner if operating conditions rise above maximum boiler design temperature.
 2. Low-Water Cutoff Switch: Float and electronic probe shall prevent burner operation on low water. Cutoff switch shall be automatic-reset type.
 3. Blocked Vent Safety Switch: Manual-reset switch factory mounted on draft diverter.
 4. Rollout Safety Switch: Factory mounted on boiler combustion chamber.
 5. Audible Alarm: Factory mounted on control panel with silence switch; shall sound alarm for above conditions.
- D. Building Management System Interface: Factory install hardware and software to enable building management system to monitor, control, and display boiler status and alarms.
 1. Hardwired Points:
 - a. Monitoring: On/off status, common trouble alarm, and low-water-level alarm.
 - b. Control: On/off operation, steam pressure adjustment.
 2. A communication interface with building management system shall enable building management system operator to remotely control and monitor the boiler from an operator

workstation. Control features available and monitoring points displayed, locally at boiler control panel shall be available through building management system.

2.7 ELECTRICAL POWER

- A. Controllers, Electrical Devices, and Wiring: Electrical devices and connections are specified in electrical Sections.

2.8 CAPACITIES AND CHARACTERISTICS

- A. Refer to Schedule on the Drawings for performance and capacity characteristics.

2.9 SOURCE QUALITY CONTROL

- A. Test and inspect factory-assembled boilers, before shipping, according to 2010 ASME Boiler and Pressure Vessel Code.
- B. Burner and Hydrostatic Test: Factory adjust burner to eliminate excess oxygen, carbon dioxide, oxides of nitrogen emissions, and carbon monoxide in flue gas and to achieve combustion efficiency; perform hydrostatic test.
- C. Allow Owner access to source quality-control testing of boilers. Notify Architect 14 days in advance of testing.

PART 3 - EXECUTION

3.1 EXAMINATION

- A. Examine roughing-in for concrete equipment bases, anchor-bolt sizes and locations, and piping and electrical connections to verify actual locations, sizes, and other conditions affecting performance of the Work.
 - 1. Final boiler locations indicated on Drawings are approximate. Determine exact locations before roughing-in for piping and electrical connections.
- B. Examine mechanical spaces for suitable conditions where boilers will be installed.
- C. Proceed with installation only after unsatisfactory conditions have been corrected.

3.2 BOILER INSTALLATION

- A. Equipment Mounting:
 - 1. Install boilers on existing cast-in-place concrete equipment base(s).
- B. Install oil-fired boilers according to NFPA 31.
- C. Assemble boiler sections in sequence and seal between each section.
- D. Assemble and install boiler trim.

- E. Install electrical devices furnished with boiler but not specified to be factory mounted.
- F. Install control wiring to field-mounted electrical devices.

3.3 CONNECTIONS

- A. Piping installation requirements are specified in Section 232213 "Steam and Condensate Heating Piping." Drawings indicate general arrangement of piping, fittings, and specialties.
- B. Install piping adjacent to boiler to allow service and maintenance.
- C. Connect oil piping full size to burner inlet with shutoff valve and union.
- D. Connect steam and condensate piping to supply-, return-, and blowdown-boiler tapings with shutoff valve and union or flange at each connection.
- E. Install piping from safety relief valves to nearest floor drain.
- F. Install piping from safety valves to drip-pan elbow and to nearest floor drain.
- G. Install piping from equipment drain connection to nearest floor drain. Piping shall be at least full size of connection. Provide an isolation valve if required.
- H. Connect breeching full size to boiler outlet. Comply with requirements in Section 235133 "Insulated Sectional Chimneys" for venting materials.

3.4 FIELD QUALITY CONTROL

- A. Testing Agency: Engage a qualified testing agency to perform tests and inspections.
- B. Manufacturer's Field Service: Engage a factory-authorized service representative to test and inspect components, assemblies, and equipment installations, including connections.
- C. Perform the following tests and inspections with the assistance of a factory-authorized service representative:
 - 1. Perform installation and startup checks according to manufacturer's written instructions.
 - 2. Leak Test: Hydrostatic test. Repair leaks and retest until no leaks exist.
 - 3. Operational Test: Start units to confirm proper motor rotation and unit operation. Adjust air-fuel ratio and combustion.
 - 4. Test and adjust controls and safeties. Replace damaged and malfunctioning controls and equipment.
 - a. Burner Test: Adjust burner to eliminate excess oxygen, carbon dioxide, oxides of nitrogen emissions, and carbon monoxide in flue gas and to achieve combustion efficiency.
 - b. Check and adjust initial operating set points and high- and low-limit safety set points of fuel supply, water level, and steam pressure.
 - c. Set field-adjustable switches and circuit-breaker trip ranges as indicated.
- D. Remove and replace malfunctioning units and retest as specified above.
- E. Performance Tests:

1. Engage a factory-authorized service representative to inspect component assemblies and equipment installations, including connections, and to conduct performance testing.
 2. Boilers shall comply with performance requirements indicated, as determined by field performance tests. Adjust, modify, or replace equipment to comply.
 3. Perform field performance tests to determine capacity and efficiency of boilers.
 - a. Test for full capacity.
 - b. Test for boiler efficiency at both low fire and high fire. Determine efficiency at each test point.
 4. Repeat tests until results comply with requirements indicated.
 5. Provide analysis equipment required to determine performance.
 6. Provide temporary equipment and system modifications necessary to dissipate the heat produced during tests if building systems are inadequate.
 7. Notify Architect in advance of test dates.
 8. Document test results in a report and submit to Architect.
- F. Boiler will be considered defective if it does not pass tests and inspections.
- G. Prepare test and inspection reports.

3.5 ADJUSTING

- A. Occupancy Adjustments: When requested within 12 months of date of Substantial Completion, provide on-site assistance in adjusting system to suit actual occupied conditions after system has been in normal operation. Provide up to two visits to Project for this purpose.

3.6 DEMONSTRATION

- A. Engage a factory-authorized service representative to train Owner's maintenance personnel to adjust, operate, and maintain boilers. Refer to Section 017900 "Demonstration and Training."

END OF SECTION 23 52 23

SECTION 26 55 68
ATHLETIC SPORTS LIGHTING

PART 1 - GENERAL

1.1 SUMMARY

A. Section Includes:

1. Luminaires, lamps, and ballasts.
2. Support structures.

B. Related Requirements:

1. Section 260010 "Supplemental Requirements for Electrical" for additional abbreviations, definitions, submittals, qualifications, testing agencies, and other Project requirements applicable to Work specified in this Section.
2. Section 260923 "Lighting Control Devices" for control of lighting.

1.2 DEFINITIONS

- A. Coefficient of Variation (CV): A statistical measure of the weighted average of all relevant illumination values for the playing area, expressed as the ratio of the standard deviation for all illuminance values to the mean illuminance value.
- B. Illuminance: The metric most commonly used to evaluate lighting systems. It is the density of luminous flux, or flow of light, reaching a surface divided by the area of that surface.
1. Horizontal Illuminance: Measurement in fc, on a horizontal surface 36 inch above ground unless otherwise indicated.
 2. Target Illuminance: Average maintained illuminance level, calculated by multiplying initial illuminance by LLF.
 3. Vertical Illuminance: Measurement in fc in four directions on a vertical surface, at an elevation coinciding with plane height of horizontal measurements.
- C. Light-Loss Factor (LLF): A factor used in calculating the level of illumination after a given time and under given conditions. It takes into account temperature, dirt accumulation on the luminaire, lamp depreciation, maintenance procedures, and atmospheric conditions. An LLF includes a recoverable LLF.
- D. Uniformity Gradient (UG): The rate of change of illuminance on the playing field, expressed as a ratio between the illuminances of adjacent measuring points on a uniform grid.

1.3 ACTION SUBMITTALS

A. Product Data:

1. For luminaires, lamps, and ballasts.
 - a. Arrange in order of luminaire designation.
 - b. Data on features, accessories, and finishes.
 - c. Physical description and dimensions of luminaires.
 - d. Ballast, including BF, UL listing and recognition, ANSI certification, and Energy Independence and Security Act of 2007 compliance.

- e. Lamps, including life, output (lumens, CCT, and CRI), and energy-efficiency data.
 - f. Photometric data and adjustment factors based on laboratory tests by, or under supervision of, qualified luminaire photometric testing laboratory, for each lighting luminaire type. Adjustment factors must be for lamps, ballasts, and accessories identical to those indicated for the luminaire as applied in this Project.
 - g. Means of attaching luminaires to supports and indication that attachment is suitable for components involved.
- B. Shop Drawings:
- 1. For nonstandard or custom luminaires.
 - a. Plans, elevations, sections, and mounting and attachment details.
 - b. Diagrams for power, signal, and control wiring.
- C. Product Schedule: For luminaires and lamps. Use same designations indicated on Drawings.
- D. Delegated Design Submittals: For interior athletic lighting, including analysis data.
- 1. Drawings and specifications for construction of lighting system.
 - 2. Manufacturer's determination of LLF used in design calculations.
 - 3. Lighting system design calculations for the following:
 - a. Target illuminance.
 - b. Point calculations of horizontal and vertical illuminance, CV, and UG at minimum grid size and area.
 - 4. Wiring requirements, including required conductors, cables, and wiring methods.
- E. Field Quality-Control Submittals:
- 1. Field quality-control reports.
- 1.4 DELIVERY, STORAGE, AND HANDLING
- A. Protect finishes of exposed surfaces by applying a strippable, temporary protective covering before shipping.
 - B. Delivery Timing Equipment On-Site: The equipment must be on-site 10-12 weeks from receipt of approved submittals and receipt of complete order information.
- 1.5 WARRANTY
- A. 10-Year Warranty: Lighting supplier shall supply a signed warranty covering the entire system for 10 years from the date of shipment. Warranty shall guarantee specified light levels. Manufacturer shall maintain specifically funded financial reserves to assure fulfillment of the warranty for the full term. Warranty does not cover weather conditions events such as lightning or hail damage, improper installation, vandalism or abuse, unauthorized repairs or alterations, or product made by other manufacturers.
 - B. Maintenance: Owner shall monitor the performance of the lighting system and will contact manufacturer in the event of a luminaire outage or other failure. Parts and labor shall be covered such that individual luminaire outages will be repaired when the usage of any field is materially impacted. Manufacturer is responsible for removal and replacement of failed luminaires, including

all parts, labor, shipping, and equipment rental associated with maintenance. Owner agrees to check fuses in the event of a luminaire outage.

1. Warranty Period: 10 years from date of Substantial Completion.

PART 2 - PRODUCTS

2.1 MANUFACTURERS

- A. Musco’s KBL solution with a 10-year parts and labor warranty is the approved product. All substitutions must provide a complete submittal package for approval as outlined in Submittal Information at the end of this section at least 10 days prior to bid. Special manufacturing to meet the standards of this specification may be required.

2.2 PERFORMANCE REQUIREMENTS

- A. Facility Type: NCAA College Basketball Court.
- B. Illumination Criteria:
 1. Illumination Levels and Design Factors: Playing surfaces shall be lit to an average target illumination level and uniformity as specified in the chart below. Lighting calculations shall be developed, and court measurements taken on the grid spacing with the minimum number of grid points specified below. Appropriate light loss factors shall be applied and submitted for the basis of design. Average illumination level shall be measured in accordance with the IESNA LM-5-04 (IESNA Guide for Photometric Measurements of Area and Sports Lighting Installations). Illumination levels shall not to drop below desired target values in accordance to IES RP-6-15, Page 2, Maintained Average Illuminance and shall be guaranteed for the full warranty period.
 2. All proposed lighting layouts must meet NCAA Guidelines.
 3. The lighting system shall have a minimum color temperature of 5000K and a CRI of 80.

| Area of Lighting | Average Target Illumination Levels | Maximum to Minimum Uniformity Ratio | Grid Points | Grid Spacing |
|-------------------------|---|--|--------------------|---------------------|
| Court | 80FC | 2:1 | 50 | 10’ x 10’ |

- C. Illumination Calculations: Computer-analyzed point method complying with IES RP-6 to optimize selection, location, and aiming of luminaires.
 1. Grid Pattern Dimensions: For playing areas of each sport correlate and reference calculated parameters to the grid areas. Each grid point represents the center of the grid area defined by the length and width of the grid spacing.

2.3 GENERAL FINISH REQUIREMENTS

- A. Protect mechanical finishes on exposed surfaces from damage by applying a strippable, temporary protective covering before shipping.
- B. Appearance of Finished Work: Noticeable variations in same piece are unacceptable. Variations in finishes of adjoining components are acceptable if they are within the range of approved Samples and can be and are assembled or installed to minimize contrast.

2.4 QUALITY CONTROL

- A. Illumination Measurements: Upon substantial completion of the project and in the presence of the Contractor, Project Engineer, Owner's Representative, and Manufacturer's Representative, illumination measurements shall be taken and verified. The illumination measurements shall be conducted in accordance with IESNA LM-5-04.
- B. Light Level Accountability
 - 1. Light levels are guaranteed not to fall below the target maintained light levels for the entire warranty period of 10 years. These levels will be specifically stated as "guaranteed" on the illumination summary provided by the manufacturer.
 - 2. The contractor/manufacturer shall be responsible for conducting initial light level testing and an additional inspection of the system, in the presence of the owner, one year from the date of commissioning of the lighting.
 - 3. The contractor/manufacturer will be held responsible for any and all changes needed to bring court to compliance for light levels and uniformities. Contractor/Manufacturer will be held responsible for any damage to the fields during these repairs.
- C. Correcting Non-Conformance: If, in the opinion of the Owner or his appointed Representative, the actual performance levels including footcandles and uniformity ratios are not in conformance with the requirements of the performance specifications and submitted information, the Manufacturer shall be required to make adjustments to meet specifications and satisfy Owner.

PART 3 - EXECUTION

3.1 EXAMINATION

- A. Examine substrates, areas, and conditions, with Installer present, for compliance with requirements for installation tolerances and other conditions affecting performance of the Work.
- B. Examine roughing-in for luminaire electrical and communications conduit to verify actual locations of connections before pole or luminaire installation.
- C. Examine foundations for suitable conditions where luminaires will be installed.
- D. Proceed with installation only after unsatisfactory conditions have been corrected.

3.2 INSTALLATION

- A. Wiring Method: Install cables in raceways, except when cables are installed within boxes and poles. Conceal raceways and cables.
 - 1. Comply with requirements in Section 260519 "Low-Voltage Electrical Power Conductors and Cables" and Section 260533 "Raceways and Boxes for Electrical Systems" for wiring connections and wiring methods.
- B. Coordination layout and installation of luminaires with other construction.
- C. Install its level, plumb, and square.
- D. Install luminaires at height as indicated on Drawings.

3.3 IDENTIFICATION

- A. Identify system components, wiring, cabling, and terminals. Comply with requirements for identification specified in Section 260553 "Identification for Electrical Systems."

3.4 FIELD QUALITY CONTROL

- A. Field tests and inspections must be witnessed by Owner.
- B. Tests and Inspections:
 - 1. After installing sports lighting system and after electrical circuits have been energized, perform proof-of-performance field measurements and analysis for compliance with requirements.
 - 2. Perform analysis to demonstrate correlation of field measurements with specified illumination quality and quantity values and corresponding computer-generated values that were submitted with engineered design documents. Submit a report of the analysis. For computer-generated values, use manufacturer's lamp lumens that are adjusted to lamp age at time of field testing.
 - 3. Report results in writing.
- C. Assemble and submit test and inspection reports.
- D. Manufacturer Services:
 - 1. Engage factory-authorized service representative to support field tests and inspections.

3.5 ADJUSTING

- A. Adjust luminaires and supports to maintain orientation and aiming as recommended by manufacturer.

END OF SECTION 26 55 68

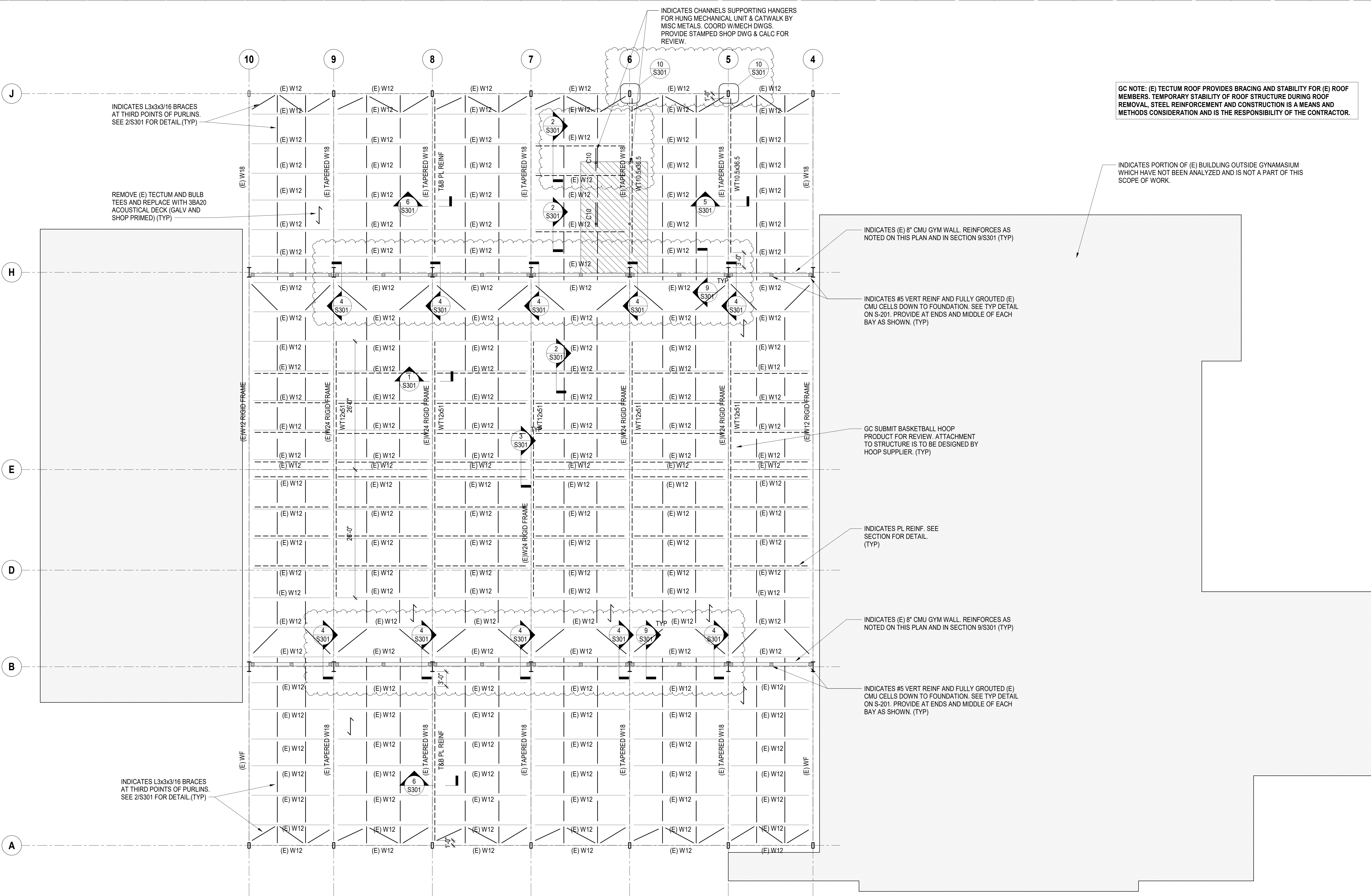

GC NOTE: (E) TECTUM ROOF PROVIDES BRACING AND STABILITY FOR (E) ROOF MEMBERS. TEMPORARY STABILITY OF ROOF STRUCTURE DURING ROOF REMOVAL, STEEL REINFORCEMENT AND CONSTRUCTION IS A MEANS AND METHODS CONSIDERATION AND IS THE RESPONSIBILITY OF THE CONTRACTOR.

INDICATES PORTION OF (E) BUILDING OUTSIDE GYMNASIUM WHICH HAVE NOT BEEN ANALYZED AND IS NOT A PART OF THIS SCOPE OF WORK.

INDICATES (E) 8" CMU GYM WALL. REINFORCES AS NOTED ON THIS PLAN AND IN SECTION 9/S301 (TYP)

INDICATES #5 VERT REINF AND FULLY GROUTED (E) CMU CELLS DOWN TO FOUNDATION. SEE TYP DETAIL ON S-201. PROVIDE AT ENDS AND MIDDLE OF EACH BAY AS SHOWN. (TYP)

GC SUBMIT BASKETBALL HOOP PRODUCT FOR REVIEW. ATTACHMENT TO STRUCTURE IS TO BE DESIGNED BY HOOP SUPPLIER. (TYP)

INDICATES PL REINF. SEE SECTION FOR DETAIL (TYP)

INDICATES (E) 8" CMU GYM WALL. REINFORCES AS NOTED ON THIS PLAN AND IN SECTION 9/S301 (TYP)

INDICATES #5 VERT REINF AND FULLY GROUTED (E) CMU CELLS DOWN TO FOUNDATION. SEE TYP DETAIL ON S-201. PROVIDE AT ENDS AND MIDDLE OF EACH BAY AS SHOWN. (TYP)

INDICATES L3x3x3/16 BRACES AT THIRD POINTS OF PURLINS. SEE 2/S301 FOR DETAIL (TYP)

REMOVE (E) TECTUM AND BULB TEES AND REPLACE WITH 3BA20 ACOUSTICAL DECK (GALV AND SHOP PRIMED) (TYP)

INDICATES L3x3x3/16 BRACES AT THIRD POINTS OF PURLINS. SEE 2/S301 FOR DETAIL (TYP)

1 T.O. GYM ROOF
SCALE: 1/8" = 1'-0"

- NOTES:
1. SEE S301 FOR TYPICAL STEEL DETAILS AND SECTIONS.
2. GC VERIFY ALL EXISTING CONDITIONS AND DIMENSIONS. NOTIFY EOR OF DISCREPANCIES.

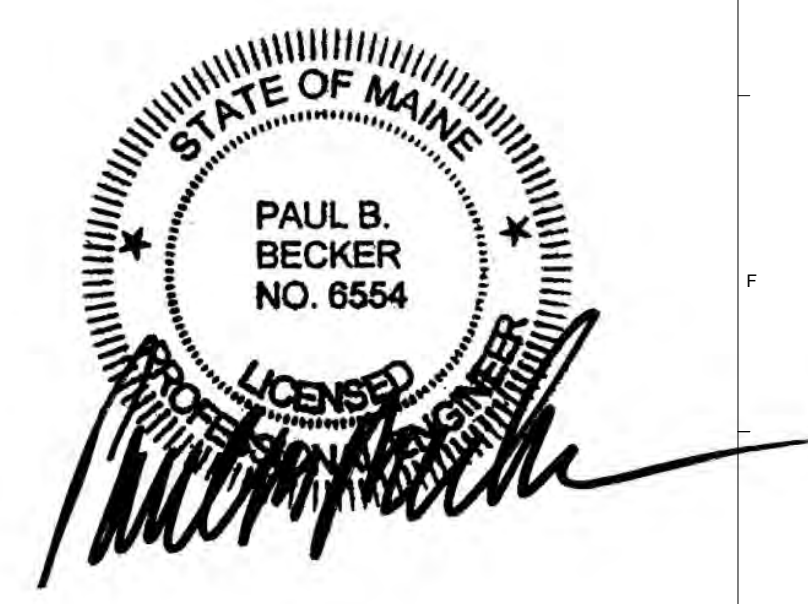

| T | ADDENDUM T | 10 FEB 2022 |
|------|--------------------|-------------|
| 0 | ISSUED FOR BIDDING | 21 JAN 2022 |
| REV. | DESCRIPTION | DATE |

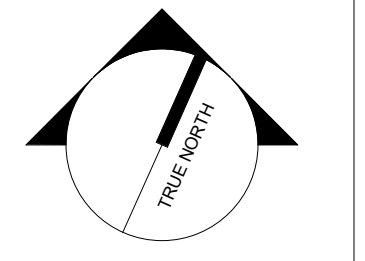

WBRC
ARCHITECTS • ENGINEERS
WWW.WBRCAE.COM
BANGOR, MAINE 207-943-4511
PORTLAND, MAINE 207-824-4511
SARASOTA, FLORIDA 941-556-8052

UMPI-WIEDEN HALL
RENOVATIONS
PROJECT: PRESQUE ISLE, MAINE
ROOF PLAN

| | |
|-----------------|--------------|
| SHEET TITLE | |
| WBRC CAD FILE | |
| PROJECT No. | P21452 |
| SCALE | 1/8" = 1'-0" |
| PROJECT MANAGER | MDP |
| DRAWN BY | |
| CHECKED BY | |
| SHEET No. | S102 |

2/11/2022 8:28:26 AM U:\aobdesk_AutoSave\Revit\394520 - UMPI WIEDEN HALL_cad\paleine@wbrcae.com.rvt

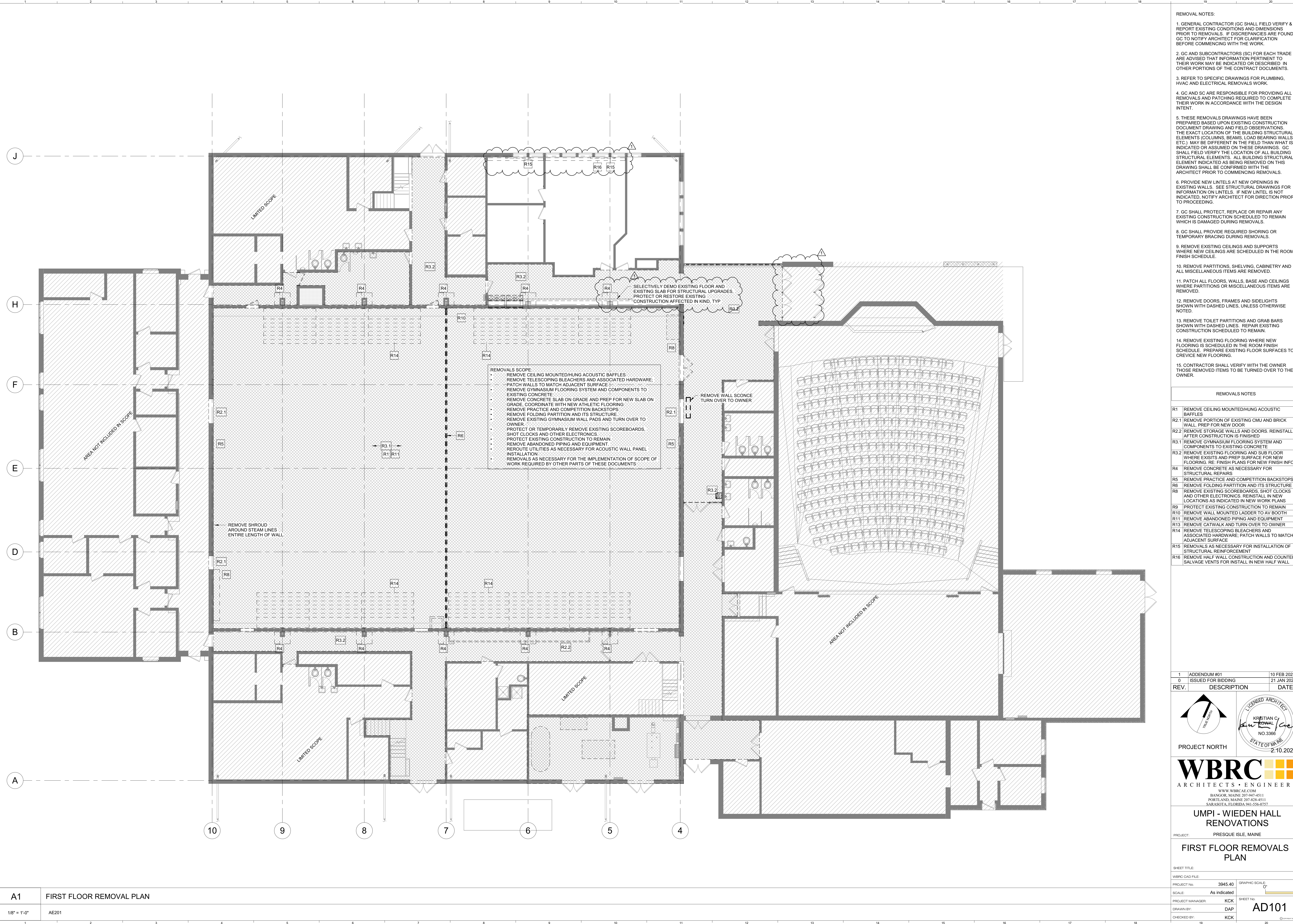

- REMOVAL NOTES:**
1. GENERAL CONTRACTOR (GC) SHALL FIELD VERIFY & REPORT EXISTING CONDITIONS AND DIMENSIONS PRIOR TO REMOVALS. IF DISCREPANCIES ARE FOUND, GC TO NOTIFY ARCHITECT FOR CLARIFICATION BEFORE COMMENCING WITH THE WORK.
 2. GC AND SUBCONTRACTORS (SC) FOR EACH TRADE ARE ADVISED THAT INFORMATION PERTINENT TO THEIR WORK MAY BE INDICATED OR DESCRIBED IN OTHER PORTIONS OF THE CONTRACT DOCUMENTS.
 3. REFER TO SPECIFIC DRAWINGS FOR PLUMBING, HVAC AND ELECTRICAL REMOVALS WORK.
 4. GC AND SC ARE RESPONSIBLE FOR PROVIDING ALL REMOVALS AND PATCHING REQUIRED TO COMPLETE THEIR WORK IN ACCORDANCE WITH THE DESIGN INTENT.
 5. THESE REMOVALS DRAWINGS HAVE BEEN PREPARED BASED UPON EXISTING CONSTRUCTION DOCUMENT DRAWING AND FIELD OBSERVATIONS. THE EXACT LOCATION OF THE BUILDING STRUCTURAL ELEMENTS (COLUMNS, BEAMS, LOAD BEARING WALLS, ETC.) MAY BE DIFFERENT IN THE FIELD THAN WHAT IS INDICATED OR ASSUMED ON THESE DRAWINGS. GC SHALL FIELD VERIFY THE LOCATION OF ALL BUILDING STRUCTURAL ELEMENTS. ALL BUILDING STRUCTURAL ELEMENTS INDICATED AS BEING REMOVED ON THIS DRAWING SHALL BE CONFIRMED WITH THE ARCHITECT PRIOR TO COMMENCING REMOVALS.
 6. PROVIDE NEW LINTELS AT NEW OPENINGS IN EXISTING WALLS. SEE STRUCTURAL DRAWINGS FOR INFORMATION ON LINTELS. IF NEW LINTEL IS NOT INDICATED, NOTIFY ARCHITECT FOR DIRECTION PRIOR TO PROCEEDING.
 7. GC SHALL PROTECT, REPLACE OR REPAIR ANY EXISTING CONSTRUCTION SCHEDULED TO REMAIN WHICH IS DAMAGED DURING REMOVALS.
 8. GC SHALL PROVIDE REQUIRED SHORING OR TEMPORARY BRACING DURING REMOVALS.
 9. REMOVE EXISTING CEILINGS AND SUPPORTS WHERE NEW CEILINGS ARE SCHEDULED IN THE ROOM FINISH SCHEDULE.
 10. REMOVE PARTITIONS, SHELVING, CABINERY AND ALL MISCELLANEOUS ITEMS ARE REMOVED.
 11. PATCH ALL FLOORS, WALLS, BASE AND CEILINGS WHERE PARTITIONS OR MISCELLANEOUS ITEMS ARE REMOVED.
 12. REMOVE DOORS, FRAMES AND SIDELIGHTS SHOWN WITH DASHED LINES, UNLESS OTHERWISE NOTED.
 13. REMOVE TOILET PARTITIONS AND GRAB BARS SHOWN WITH DASHED LINES. REPAIR EXISTING CONSTRUCTION SCHEDULED TO REMAIN.
 14. REMOVE EXISTING FLOORING WHERE NEW FLOORING IS SCHEDULED IN THE ROOM FINISH SCHEDULE. PREPARE EXISTING FLOOR SURFACES TO RECEIVE NEW FLOORING.
 15. CONTRACTOR SHALL VERIFY WITH THE OWNER THOSE REMOVED ITEMS TO BE TURNED OVER TO THE OWNER.

| REMOVALS NOTES | |
|----------------|--|
| R1 | REMOVE CEILING MOUNTED/HUNG ACOUSTIC BAFFLES |
| R2.1 | REMOVE PORTION OF EXISTING CMU AND BRICK WALL. PREP FOR NEW DOOR |
| R2.2 | REMOVE STORAGE WALLS AND DOORS. REINSTALL AFTER CONSTRUCTION IS FINISHED |
| R3.1 | REMOVE GYMNASIUM FLOORING SYSTEM AND COMPONENTS TO EXISTING CONCRETE |
| R3.2 | REMOVE EXISTING FLOORING AND SUB FLOOR WHERE EXISTS AND PREP SURFACE FOR NEW FLOORING. RE-FINISH PLANS FOR NEW FINISH INFO |
| R4 | REMOVE CONCRETE AS NECESSARY FOR STRUCTURAL REPAIRS |
| R5 | REMOVE PRACTICE AND COMPETITION BACKSTOPS |
| R6 | REMOVE FOLDING PARTITION AND ITS STRUCTURE |
| R8 | REMOVE EXISTING SCOREBOARDS, SHOT CLOCKS AND OTHER ELECTRONICS. REINSTALL IN NEW LOCATIONS AS INDICATED IN NEW WORK PLANS |
| R9 | PROTECT EXISTING CONSTRUCTION TO REMAIN |
| R10 | REMOVE WALL MOUNTED LADDER TO AV BOOTH |
| R11 | REMOVE ABANDONED PIPING AND EQUIPMENT |
| R13 | REMOVE CATWALK AND TURN OVER TO OWNER |
| R14 | REMOVE TELESCOPING BLEACHERS AND ASSOCIATED HARDWARE. PATCH WALLS TO MATCH ADJACENT SURFACE |
| R15 | REMOVALS AS NECESSARY FOR INSTALLATION OF STRUCTURAL REINFORCEMENT |
| R16 | REMOVE HALF WALL CONSTRUCTION AND COUNTER. SALVAGE VENTS FOR INSTALL IN NEW HALF WALL |

| 1 | ADDENDUM #01 | 10 FEB 2022 |
|------|--------------------|-------------|
| 0 | ISSUED FOR BIDDING | 21 JAN 2022 |
| REV. | DESCRIPTION | DATE |

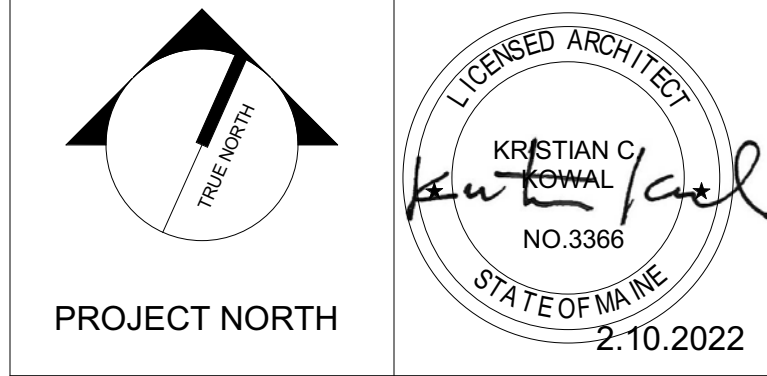

PROJECT NORTH

WBRC
ARCHITECTS • ENGINEERS

WWW.WBRCAE.COM
BANGOR, MAINE 207-943-4511
PORTLAND, MAINE 207-828-4511
SARASOTA, FLORIDA 941-556-8372

UMPI - WIEDEN HALL RENOVATIONS

PROJECT: PRESQUE ISLE, MAINE

FIRST FLOOR REMOVALS PLAN

| | |
|------------------|--------------|
| SHEET TITLE: | AD101 |
| WBRC CAD FILE: | |
| PROJECT No: | 3945.40 |
| SCALE: | As indicated |
| PROJECT MANAGER: | KCK |
| DRAWN BY: | DAP |
| CHECKED BY: | KCK |

A1 FIRST FLOOR REMOVAL PLAN

1/8" = 1'-0"

AE201

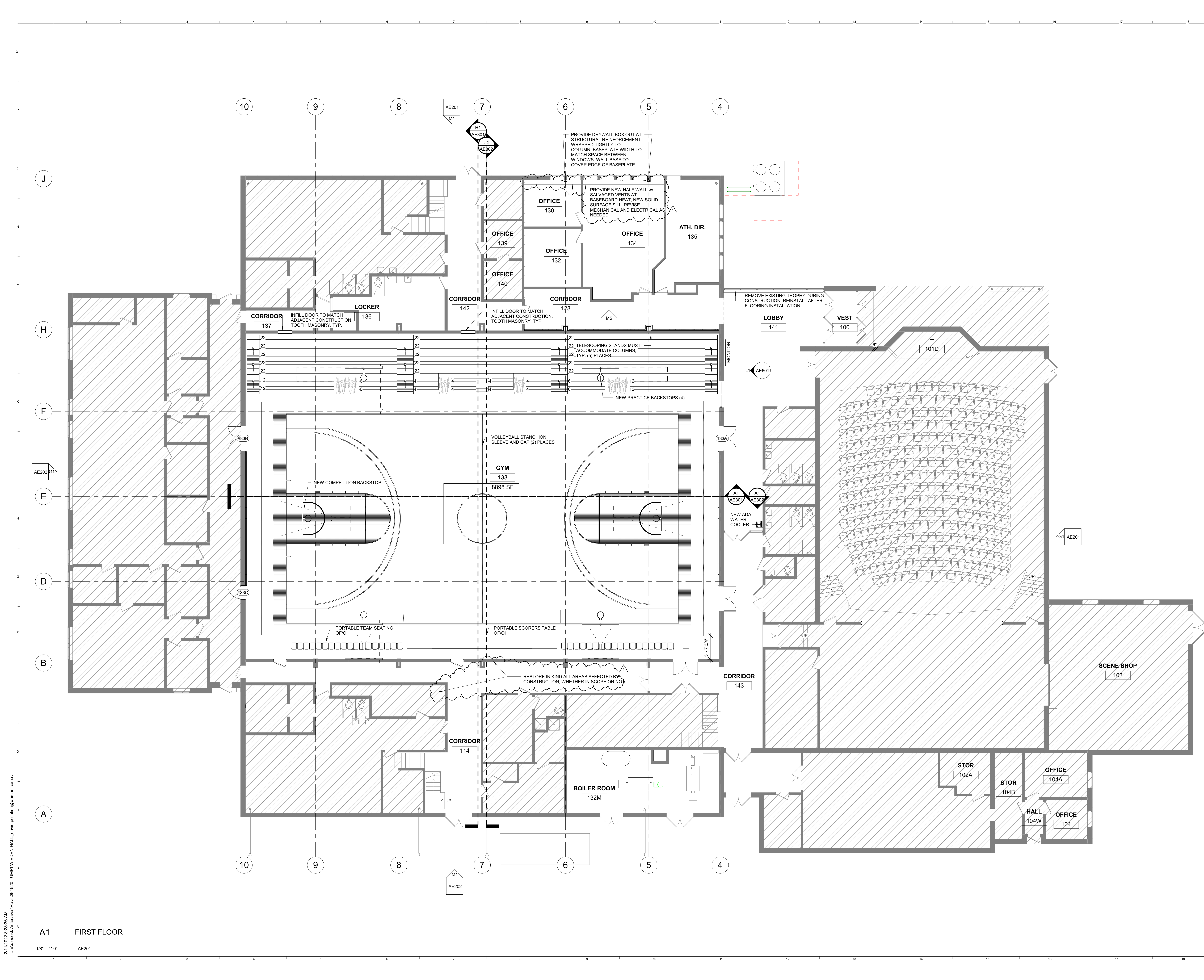

- GENERAL NOTES:**
1. ALL WALL PARTITION TYPES ARE M2 UNLESS NOTED OTHERWISE. SEE SHEET AE501 FOR PARTITION TYPES.
 2. REFER TO SHEET AE401 ENLARGED PLANS FOR ADDITIONAL INFORMATION.
 3. REFER TO G1002 SHEET FOR ALL ABBREVIATIONS AND SYMBOLS.
 4. REFER TO ALL DRAWINGS INCLUDING ARCHITECTURAL, CIVIL, STRUCTURAL, MECHANICAL, PLUMBING, AND ELECTRICAL DRAWINGS FOR ADDITIONAL GENERAL NOTES, ABBREVIATIONS, AND SYMBOLS.
 5. VERIFY ALL EQUIPMENT OPENINGS & RECOMMENDATIONS. LOCATION AND SIZES SHOWN ARE FOR INTENT PURPOSES ONLY. ADJUST TOUGH OPENINGS AND LOCATIONS AS REQUIRED PER ACTUAL EQUIPMENT.
 6. DOOR JAMBS ARE 4" FROM NEAREST ADJACENT INTERSECTING PARTITION UNLESS NOTED OTHERWISE. SEE DOOR DETAILS FOR FURTHER INFORMATION.
 7. G.C. TO PROVIDE & INSTALL ALL IN-WALL OR IN-CEILING BLOCKING / BRACING AS REQUIRED FOR ALL MILLWORK ITEMS, EQUIPMENT, SHELVING, AND ACCESSORIES WHETHER ITEMS ARE BY G.C. OR OTHERS COORDINATE WITH OWNER.
 8. G.C. SHALL BE RESPONSIBLE FOR LAYING OUT THE SPACE PRIOR TO COMMENCING WORK AND SHALL NOTIFY THE ARCHITECT AND OWNER OF ANY DISCREPANCIES.
 9. ALL CONCRETE MASONRY UNITS AND MORTAR TO INCLUDE AN INTEGRAL WATER REPELLENT.
 10. REFER TO SHEET AE601 FOR DOOR SCHEDULE AND FRAMING TYPES.
 11. REFER TO SHEET AE602 WINDOW TYPES AND FRAME ELEVATIONS.
 12. REFER TO SHEET AE701 FOR EQUIPMENT AND FURNITURE INFORMATION.
 13. ALL EXTERIOR DIMENSIONS ARE TO FACE STUD AND / OR FACE OF FOUNDATION AND MASONRY UNLESS SPECIFICALLY NOTED OTHERWISE.
 14. ALL INTERIOR DIMENSIONS SHOWN ARE TO FACE OF FRAMING UNLESS SPECIFICALLY NOTED OTHERWISE.
 15. ALL DIMENSIONS SHOWN LOCATING WINDOWS ARE TO CENTERLINE OF WINDOW, UNLESS SPECIFICALLY NOTED OTHERWISE.
 16. REFER TO SHEET G1004 FOR CODE COMPLIANCE PLAN, CODE REFERENCE INFORMATION AND FIRE RATED PARTITIONS AND SPACES. ALL MECHANICAL, ELECTRICAL, AND PLUMBING PENETRATIONS THROUGH FIRE RATED CONSTRUCTION SHALL BE SLEEVED, FIRE SAVED AND / OR HAVE FIRE DAMPERS EQUIVALENT TO THE HOURLY FIRE RATING OF THE CONSTRUCTION.
 17. ALL DRAWINGS ARE OF EQUAL IMPORTANCE IN DEFINING THE WORK OF THE CONTRACT DOCUMENTS. CONTRACTORS SHALL REVIEW ALL DRAWINGS BEFORE THE INSTALLATION OF THEIR WORK. SHOULD THERE BE A DISCREPANCY WITHIN AND BETWEEN THE DRAWINGS THAT WOULD CAUSE AN AWKWARD OR IMPROPER INSTALLATION NOTIFY ARCHITECT FOR CLARIFICATION PRIOR TO INSTALLATION OF SAID WORK. ANY WORK INSTALLED IN CONFLICT WITH THE ARCHITECTURAL DRAWINGS, SHALL BE CORRECTED BY CONTRACTOR AT THEIR EXPENSE AND AT NO ADDITIONAL COST TO THE OWNER OR ARCHITECT.
 18. DO NOT SCALE DRAWINGS. THE DRAWINGS ARE NOT NECESSARILY TO SCALE - USE GIVEN DIMENSIONS. CONTRACTOR SHALL VERIFY ALL CONDITIONS AND DIMENSIONS AT THE JOB SITE PRIOR TO THE START OF CONSTRUCTION. IF DISCREPANCIES ARE FOUND, NOTIFY ARCHITECT FOR CLARIFICATION BEFORE COMMENCING THE WORK.
 19. DASHED PLAN ELEMENTS WILL BE PROVIDED BY OWNER AND ARE SHOWN FOR COORDINATION ONLY.
 20. DETAILS NOT SHOWN ARE SIMILAR IN CHARACTER TO THOSE SHOWN, WHERE SPECIFIC DIMENSIONS, DETAILS, OR DESIGN INTENT CANNOT BE DETERMINED CONSULT ARCHITECT BEFORE PROCEEDING WITH THE WORK.
 21. ALL PITCHED FLOOR AREAS SHOWN WITH PITCH LINES SHALL SLOPE AT 1/4" PER FOOT UNLESS OTHERWISE NOTED. PROVIDE A SLAB DEPRESSION AT ALL FLOOR DRAINS WHERE PITCH LINES ARE NOT SHOWN ON PLAN.
 22. FINISH FLOOR ELEVATIONS ARE TO TOP OF CONCRETE, UNLESS OTHERWISE NOTED.
 23. INSTALL ALL RECESSED CABINETS, PANELS, BOXES LOCATED IN FIRE-RATED PARTITIONS TO MAINTAIN THE FIRE-RATED CONSTRUCTION.
 24. REFER TO MECHANICAL AND ELECTRICAL CONTRACTORS DRAWINGS AND MANUFACTURERS TEMPLATE DRAWINGS FOR ALL MECHANICAL AND ELECTRICAL EQUIPMENT SUPPORTS, BOLT SETTING TEMPLATES, ISOLATIONS, SPRING ISOLATION, ETC. NOT SHOWN ON THE DRAWINGS.
 25. OWNER FURNISHED ITEMS THE G.C. SHALL COORDINATE AND PROVIDE ELECTRICAL, PLUMBING, AND MECHANICAL CONNECTIONS FOR ALL EQUIPMENT.

| | | |
|---|--------------------|-------------|
| 1 | ADDENDUM #01 | 10 FEB 2022 |
| 0 | ISSUED FOR BIDDING | 21 JAN 2022 |

| REV. | DESCRIPTION | DATE |
|------|-------------|------|
| | | |

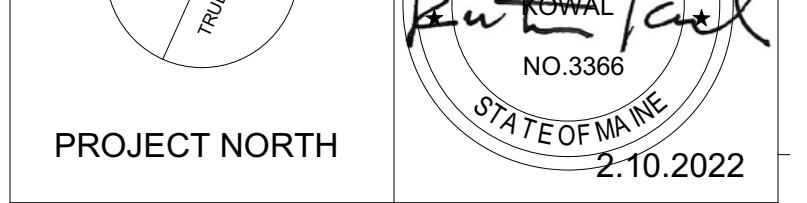

PROJECT NORTH

WBRC
ARCHITECTS • ENGINEERS

WWW.WBRCAE.COM
BANGOR, MAINE 207-943-4511
PORTLAND, MAINE 207-824-4511
SARASOTA, FLORIDA 941-556-8722

UMPI - WIEDEN HALL RENOVATIONS

PROJECT: PRESQUE ISLE, MAINE

FIRST FLOOR PLAN

| | |
|------------------|--------------|
| SHEET TITLE: | |
| WBRC CAD FILE: | |
| PROJECT No: | 3945.40 |
| SCALE: | As indicated |
| PROJECT MANAGER: | KCK |
| DRAWN BY: | DAP |
| CHECKED BY: | KCK |
| GRAPHIC SCALE: | 0' 1" |
| SHEET No: | AE101 |

2/11/2022 8:28:36 AM U:\Autodesk\Autosaves\Revit\394520 - UMPI WIEDEN HALL - UmpI_wieden_hall_cad\dwg\palestine@wbrc.com.rvt

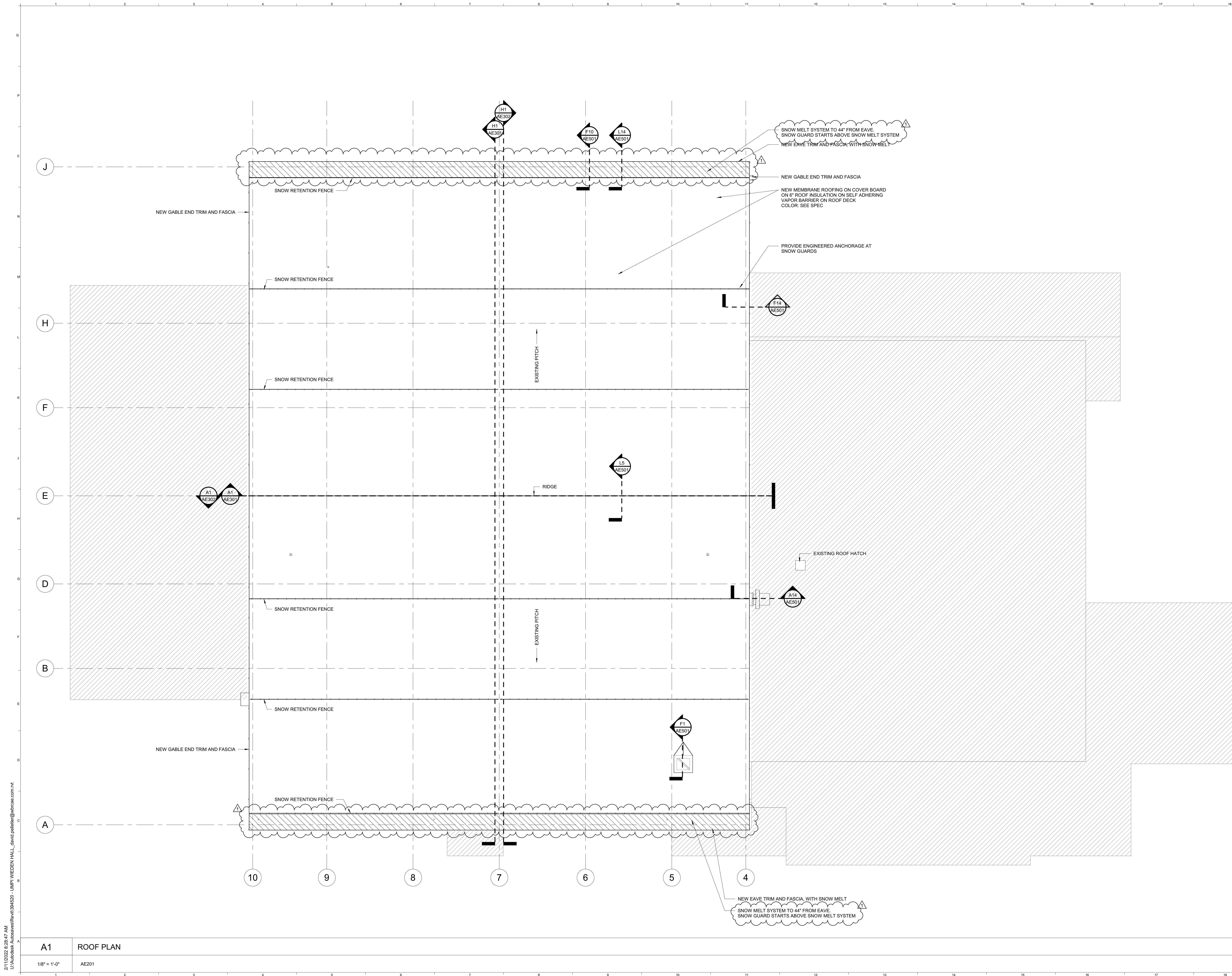

- ROOF NOTES:**
- SEE AE501 FOR ROOF DETAILS
 - ALL EQUIPMENT CURBS TO BE 12" MIN. ABOVE ROOF MEMBRANE AT HIGH SIDE
 - ALL EQUIPMENT CRICKETS TO SLOPE 1/2" PER 1'-0" MIN. PROVIDE CRICKETS AT HIGH SIDE OF CURBS TO ALLOW ADEQUATE DRAINAGE

| | | |
|---|--------------------|-------------|
| 1 | ADDENDUM #01 | 10 FEB 2022 |
| 0 | ISSUED FOR BIDDING | 21 JAN 2022 |

| REV. | DESCRIPTION | DATE |
|------|-------------|------|
| | | |

PROJECT NORTH

LICENCED ARCHITECT
KRISTIAN C. [Signature]
NO. 3366
STATE OF MAINE
2-10-2022

WBRC
ARCHITECTS • ENGINEERS

WWW.WBRCAE.COM
BANGOR, MAINE 207-943-4511
PORTLAND, MAINE 207-824-4511
SARASOTA, FLORIDA 941-556-8757

UMPI - WIEDEN HALL RENOVATIONS

PROJECT: PRESQUE ISLE, MAINE

ROOF PLAN

| | |
|------------------|--------------|
| SHEET TITLE: | |
| WBRC CAD FILE: | |
| PROJECT No: | 3945.40 |
| SCALE: | As indicated |
| PROJECT MANAGER: | KCK |
| DRAWN BY: | DAP |
| CHECKED BY: | KCK |
| SHEET No: | AE103 |

2/11/2022 8:28:47 AM U:\Autodesk\Autodesk\Revit\394520 - UMPI WIEDEN HALL_cad\paleine@wbrc.com.rvt

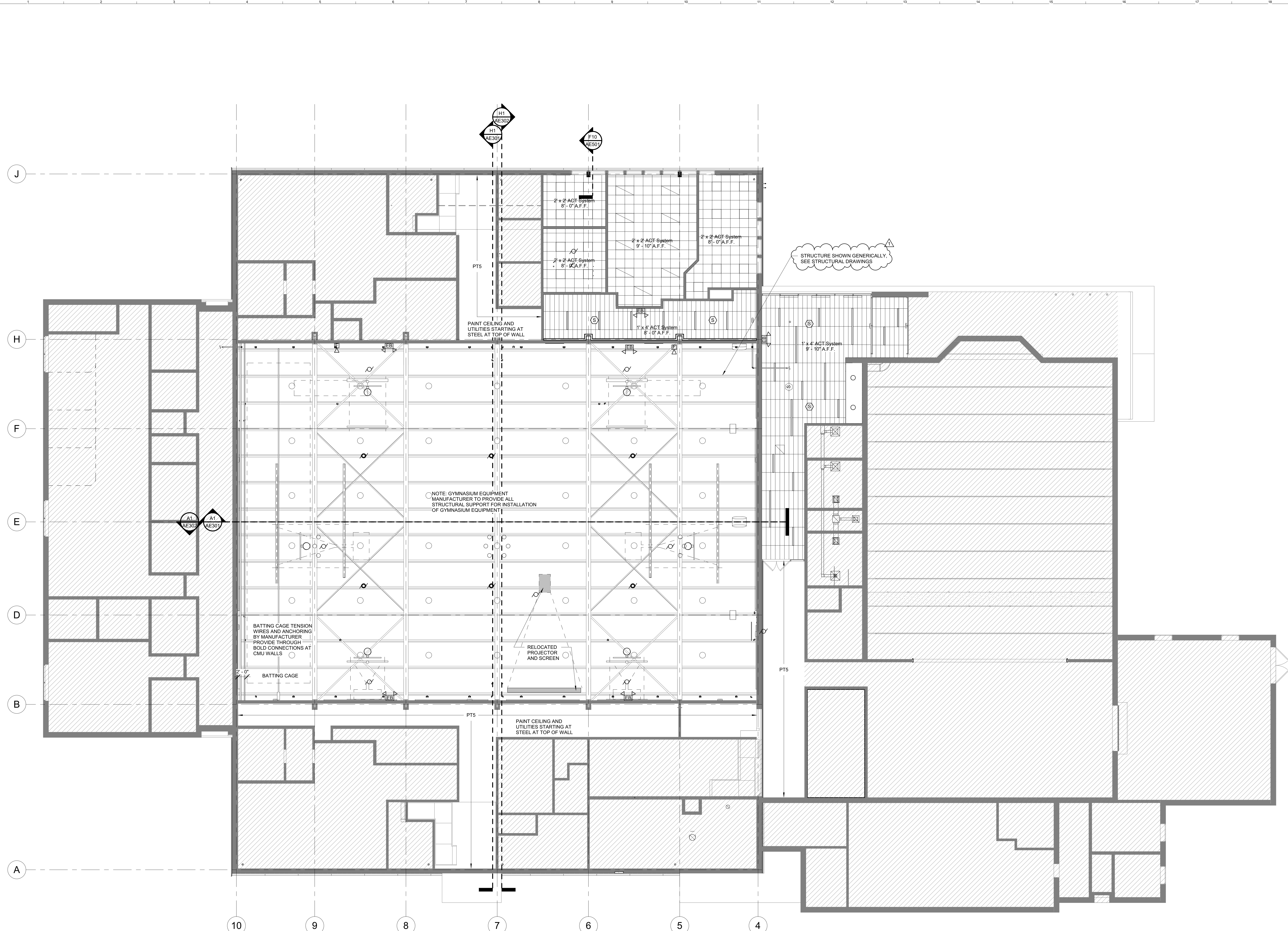

CEILING LEGEND

| | |
|--|---|
| | GWB @ 9'-0" A.F.F. ATTACHED TO HM STUD |
| | ACOUSTICAL TILE CEILING 2'-0" x 2'-0" ON METAL SUSPENSION GRID: APC-1 |
| | ACOUSTICAL TILE CEILING 2'-0" x 4'-0" ON METAL SUSPENSION GRID: APC-2 |

ELECTRICAL SYMBOLS INDICATING LIGHTING LOCATIONS. REFER TO EL SHEETS FOR SIZE/TYPE OF LIGHTING FIXTURE

MECHANICAL SYMBOLS INDICATING SUPPLY DIFFUSER OR EXHAUST/RETURN GRILLE LOCATIONS. REFER TO MH SHEETS FOR SIZE/TYPE OF DIFFUSER/GRILLE

- NOTES:**
- ALL CEILINGS TO BE X-X" AFF UNLESS NOTED OTHERWISE
 - REFER TO SHEET G1002 FOR ALL ABBREVIATIONS
 - CONTRACTOR TO VERIFY LOCATIONS OF MAIN CEILING TEES BEFORE PROCEEDING WITH FIXTURE INSTALLATION. NOTIFY ARCHITECT OF INTERFERENCES.
 - NOTIFY ARCHITECT OF ANY DISCREPANCIES BETWEEN ARCHITECTURAL REFLECTED CEILING PLANS AND ELECTRICAL LIGHTING PLANS PRIOR TO CONSTRUCTION.
 - REFER TO ELECTRICAL PLANS FOR LOCATIONS OF STROBES AND EXIT SIGNS.
 - ALL CEILING GRILLES, TRIM EDGES AND SLOT DIFFUSERS TO MATCH ADJACENT CEILING COLOR.
 - ALL SPRINKLER HEADS TO OCCUR AT CENTER OF TILES.
 - LAYOUT TILES AS SHOWN IN REFLECTED CEILING PLANS.
 - REFER TO SPECIFICATION SECTION 09511 FOR ALL ACOUSTICAL PANEL CEILING TYPES.
 - SEE AF SHEETS FOR ROOM FINISH SCHEDULE FOR CEILING FINISH INFORMATION.
 - WHERE NO CEILING MATERIAL IS SHOWN THE STRUCTURE ABOVE IS TO BE EXPOSED, U.N.O.
 - SEE EL SHEETS FOR CONTINUED LIGHTING INFORMATION
 - SEE MH SHEETS FOR CONTINUED MECHANICAL INFORMATION.

| 1 | ADDENDUM #01 | 10 FEB 2022 |
|------|--------------------|-------------|
| 0 | ISSUED FOR BIDDING | 21 JAN 2022 |
| REV. | DESCRIPTION | DATE |

PROJECT NORTH

WBRC
ARCHITECTS • ENGINEERS

WWW.WBRC.AE.COM
BANGOR, MAINE 207-943-4511
PORTLAND, MAINE 207-828-4511
SARASOTA, FLORIDA 941-556-8757

UMPI - WIEDEN HALL RENOVATIONS

PROJECT: PRESQUE ISLE, MAINE

REFLECTED CEILING PLAN

| | | | |
|------------------|--------------|----------------|------------|
| SHEET TITLE: | | A1 | |
| WBRC CAD FILE: | | AE201 | |
| PROJECT No: | 3945.40 | GRAPHIC SCALE: | 1" = 1'-0" |
| SCALE: | 1/8" = 1'-0" | CHECKED BY: | KCK |
| PROJECT MANAGER: | KCK | DRAWN BY: | DAP |
| CHECKED BY: | KCK | SHEET No: | AE104 |

2/11/2022 8:28:56 AM U:\Autodesk\Autodesk\Revit\394540 - UMPI WIEDEN HALL - Umpi\wieden_hall_cad\wieden_hall_reflected_ceiling.rvt

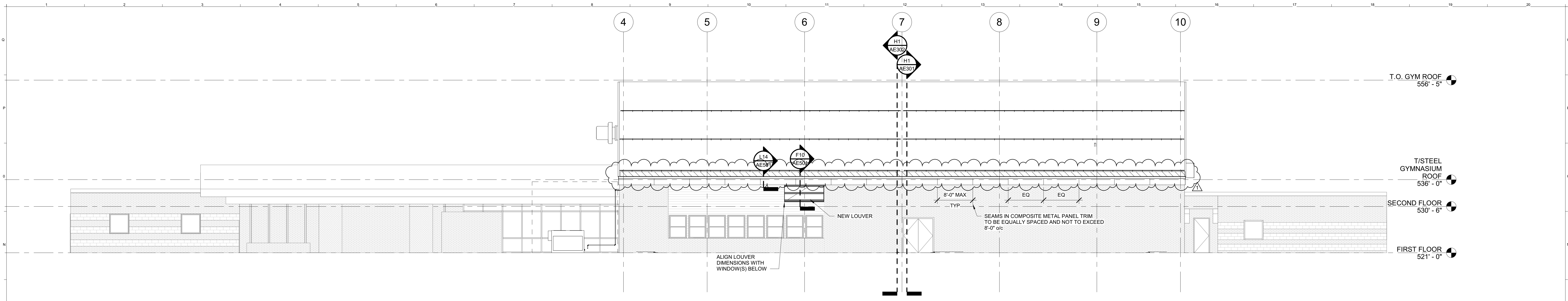

M1 BUILDING ELEVATION - NORTH

1/8" = 1'-0" AD101

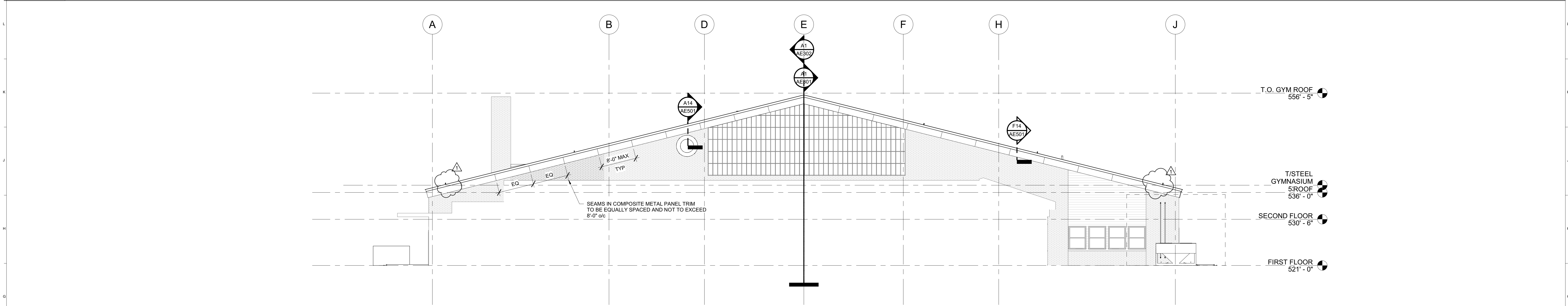

G1 BUILDING ELEVATION - EAST

1/8" = 1'-0" AD101

| 1 | ADDENDUM #01 | 10 FEB 2022 |
|------|--------------------|-------------|
| 0 | ISSUED FOR BIDDING | 21 JAN 2022 |
| REV. | DESCRIPTION | DATE |

WWW.WBRCAE.COM
 BANGOR, MAINE 207-643-4511
 PORTLAND, MAINE 207-874-4511
 SARASOTA, FLORIDA 941-556-8757

UMPI - WIEDEN HALL RENOVATIONS

PROJECT: PRESQUE ISLE, MAINE

BUILDING ELEVATIONS

| | |
|------------------|--------------|
| SHEET TITLE: | |
| WBRC CAD FILE: | |
| PROJECT No: | 3945.40 |
| SCALE: | 1/8" = 1'-0" |
| PROJECT MANAGER: | Approver |
| DRAWN BY: | Author |
| CHECKED BY: | Checker |

AE201

2/11/2022 8:29:07 AM U:\Autodesk\Autosaves\Revit\394520 - UMPI WIEDEN HALL_cad\paleini@wbrc.com.rvt

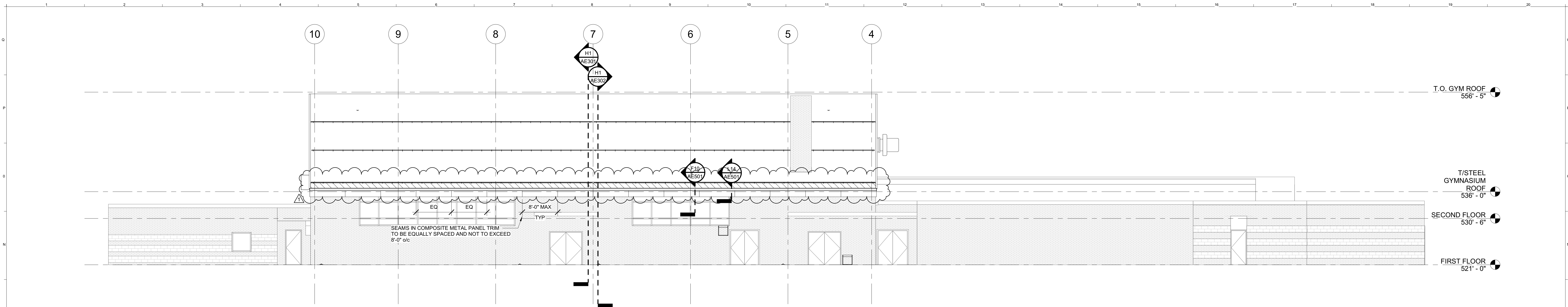

M1 BUILDING ELEVATION - SOUTH

1/8" = 1'-0" AD101

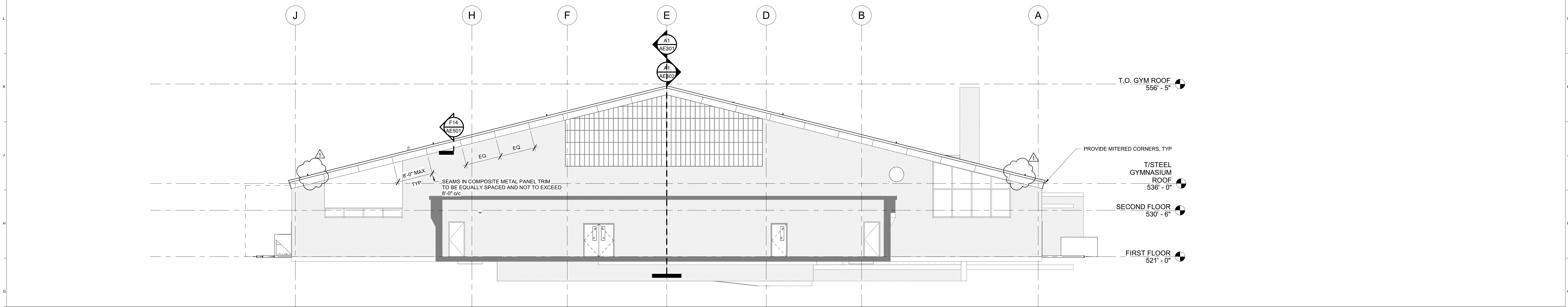

G1 BUILDING ELEVATION - WEST

1/8" = 1'-0" AD101

| 1 | ADDENDUM #01 | 10 FEB 2022 |
|------|--------------------|-------------|
| 0 | ISSUED FOR BIDDING | 21 JAN 2022 |
| REV. | DESCRIPTION | DATE |

PROJECT NORTH

WWW.WBRC.AE.COM
 BANGOR, MAINE 207-945-4511
 PORTLAND, MAINE 207-878-4511
 SARASOTA, FLORIDA 941-556-8757

UMPI - WIEDEN HALL RENOVATIONS
 PROJECT: PRESQUE ISLE, MAINE
BUILDING ELEVATIONS

SHEET TITLE: _____
 WBRC CAD FILE: _____
 PROJECT No: 3945.40 GRAPHIC SCALE: 0' 1"
 SCALE: 1/8" = 1'-0" _____
 PROJECT MANAGER: Approver SHEET No: AE202
 DRAWN BY: Author
 CHECKED BY: Checker

2/11/2022 8:28:19 AM
 U:\Autodesk\Autosaves\Revit\394520 - UMPI WIEDEN HALL_cad\paleine@wbrc.ae.com.rvt

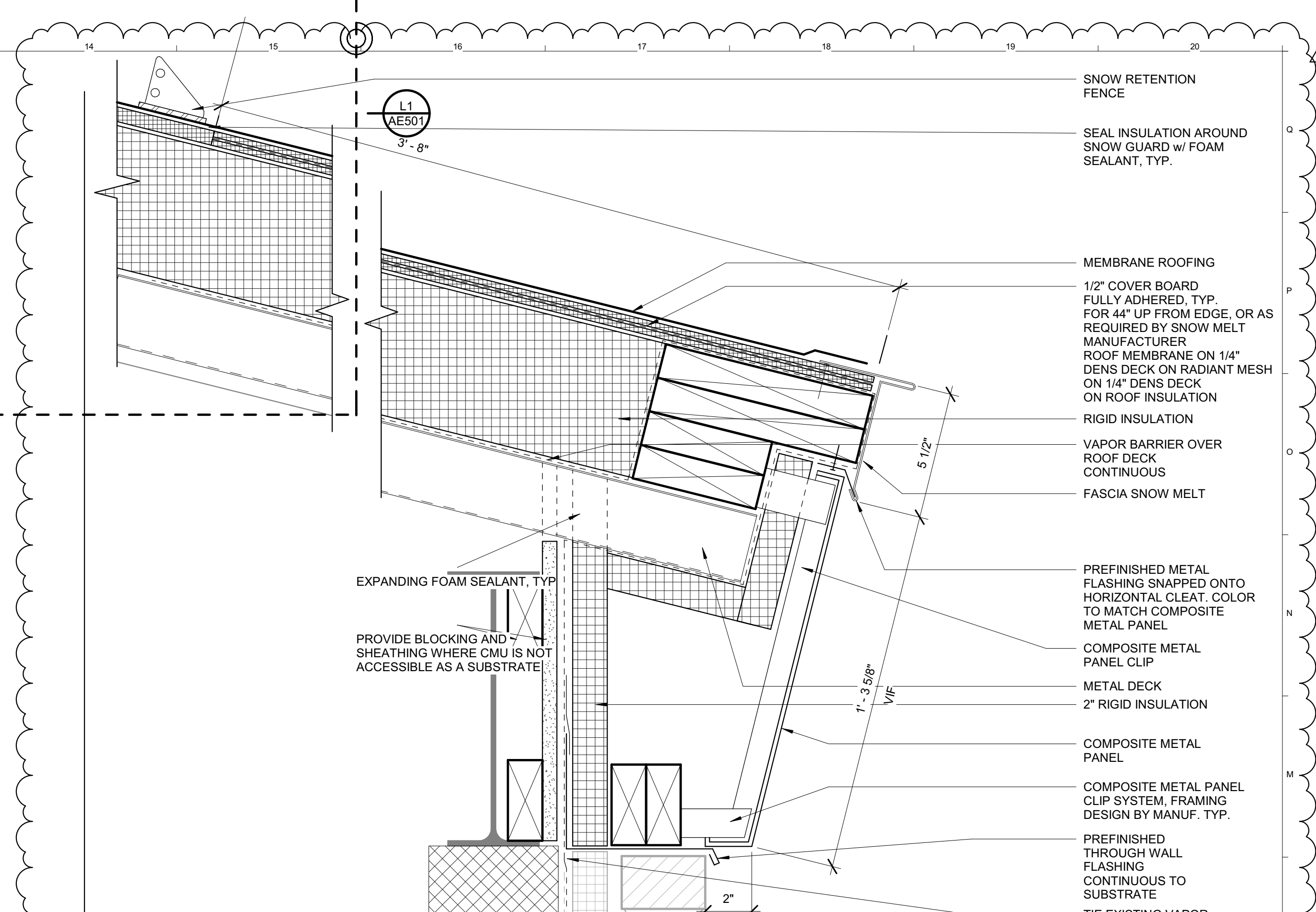
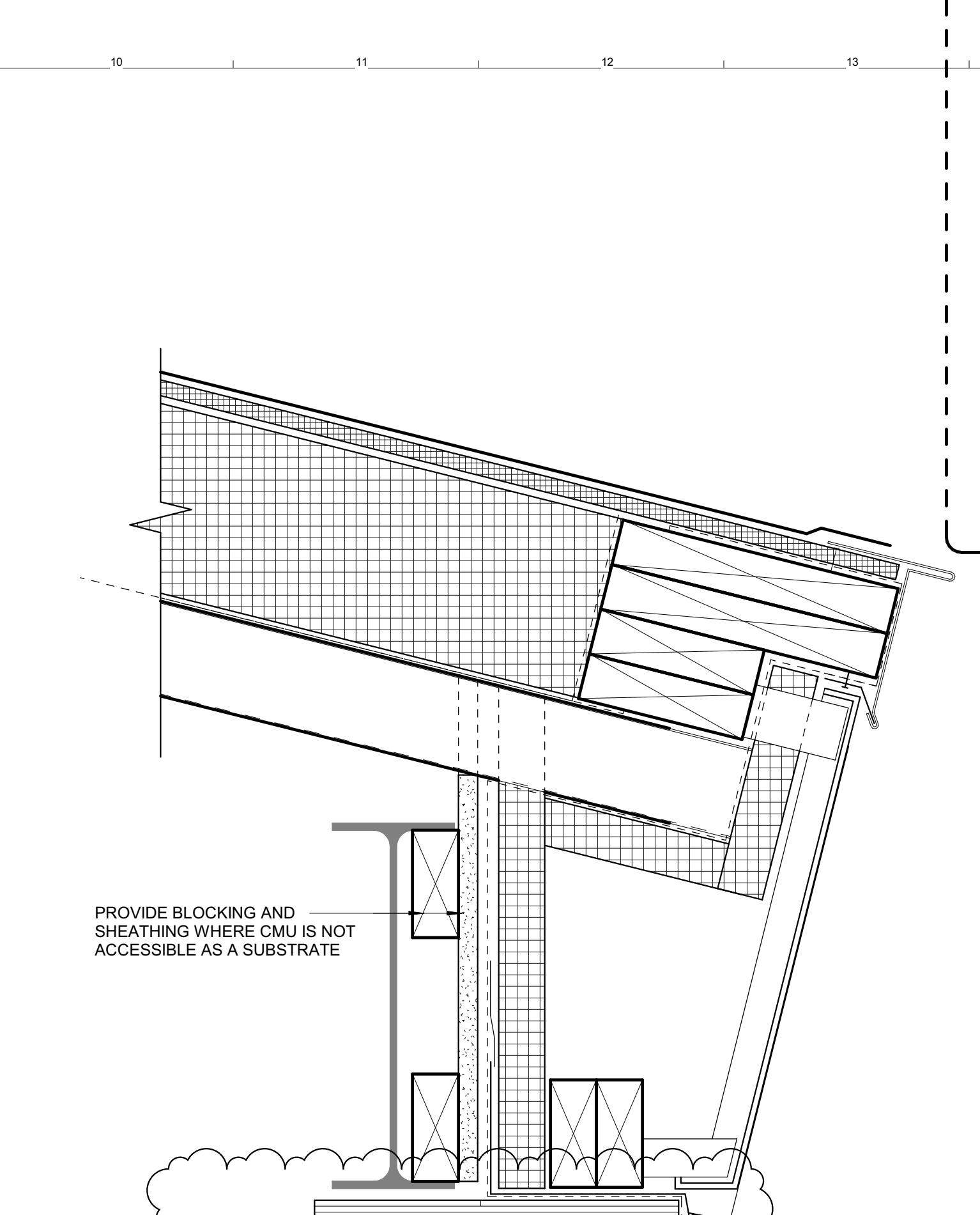
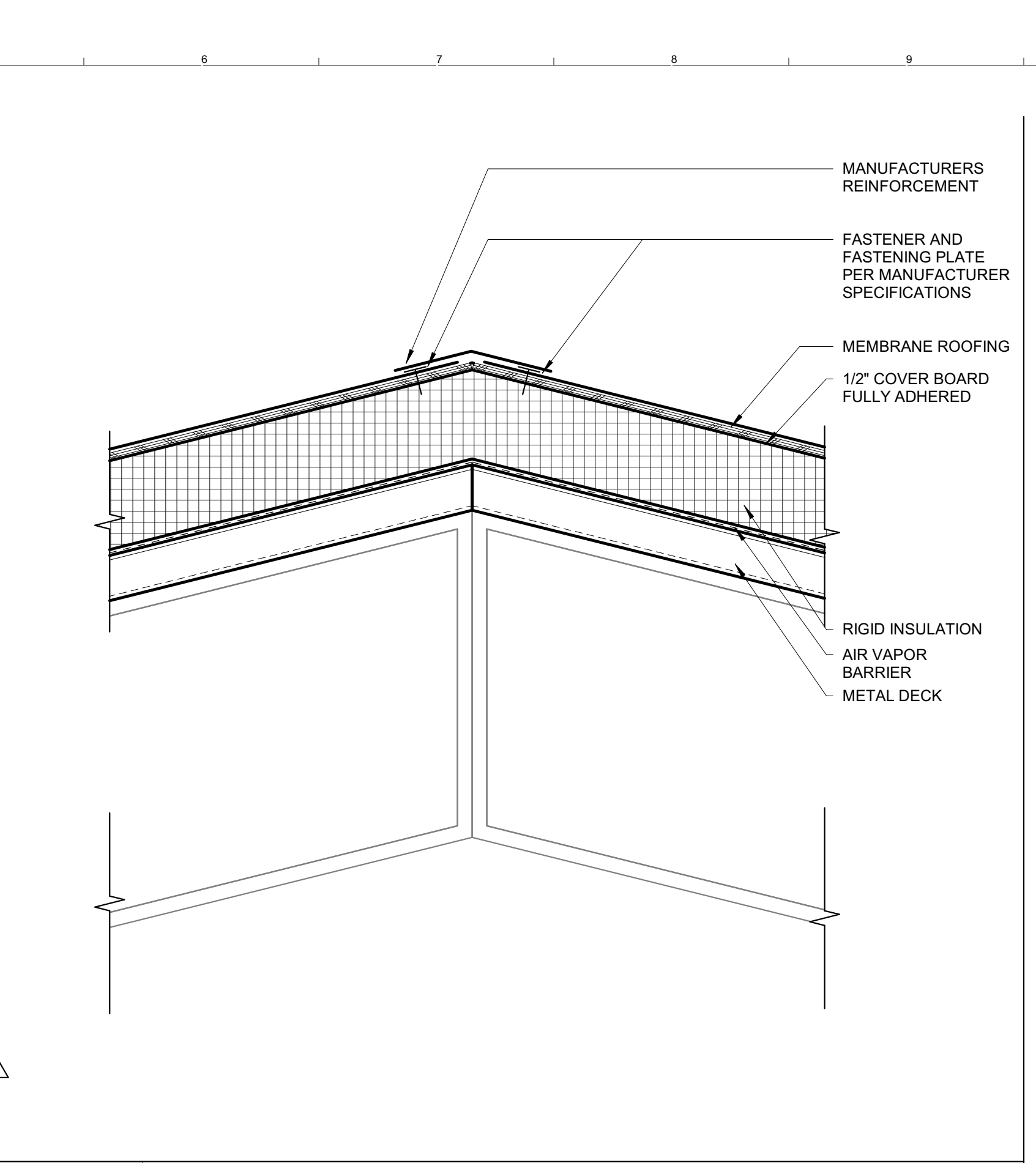
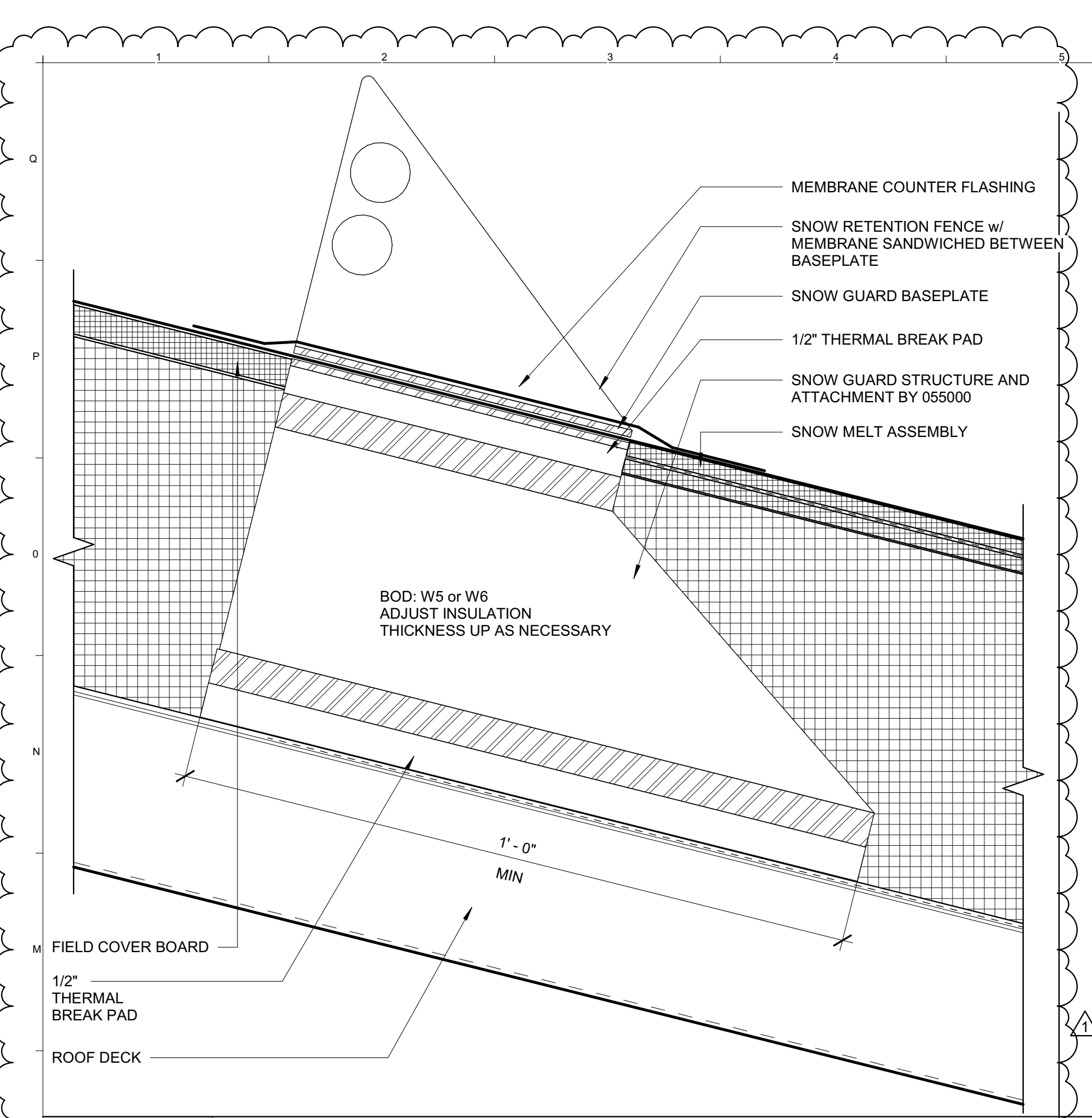

L1 SNOW RETENTION FENCE DETAIL
 6" = 1'-0" AE501

L5 RIDGE DETAIL
 1 1/2" = 1'-0" AE103

F10 EAVE AND LOUVER DETAIL
 3" = 1'-0" AE102

L14 EAVE DETAIL
 3" = 1'-0" AE103

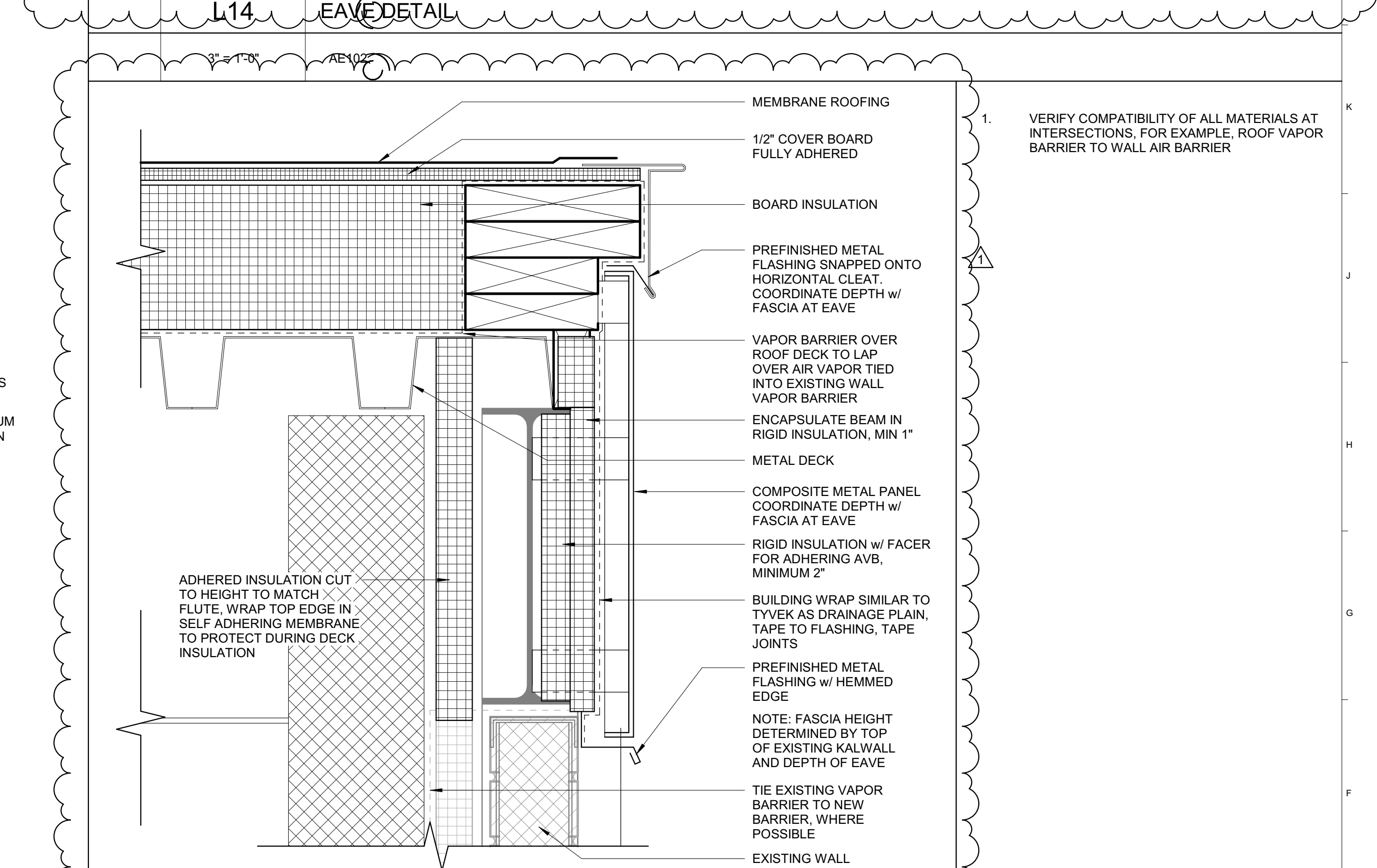
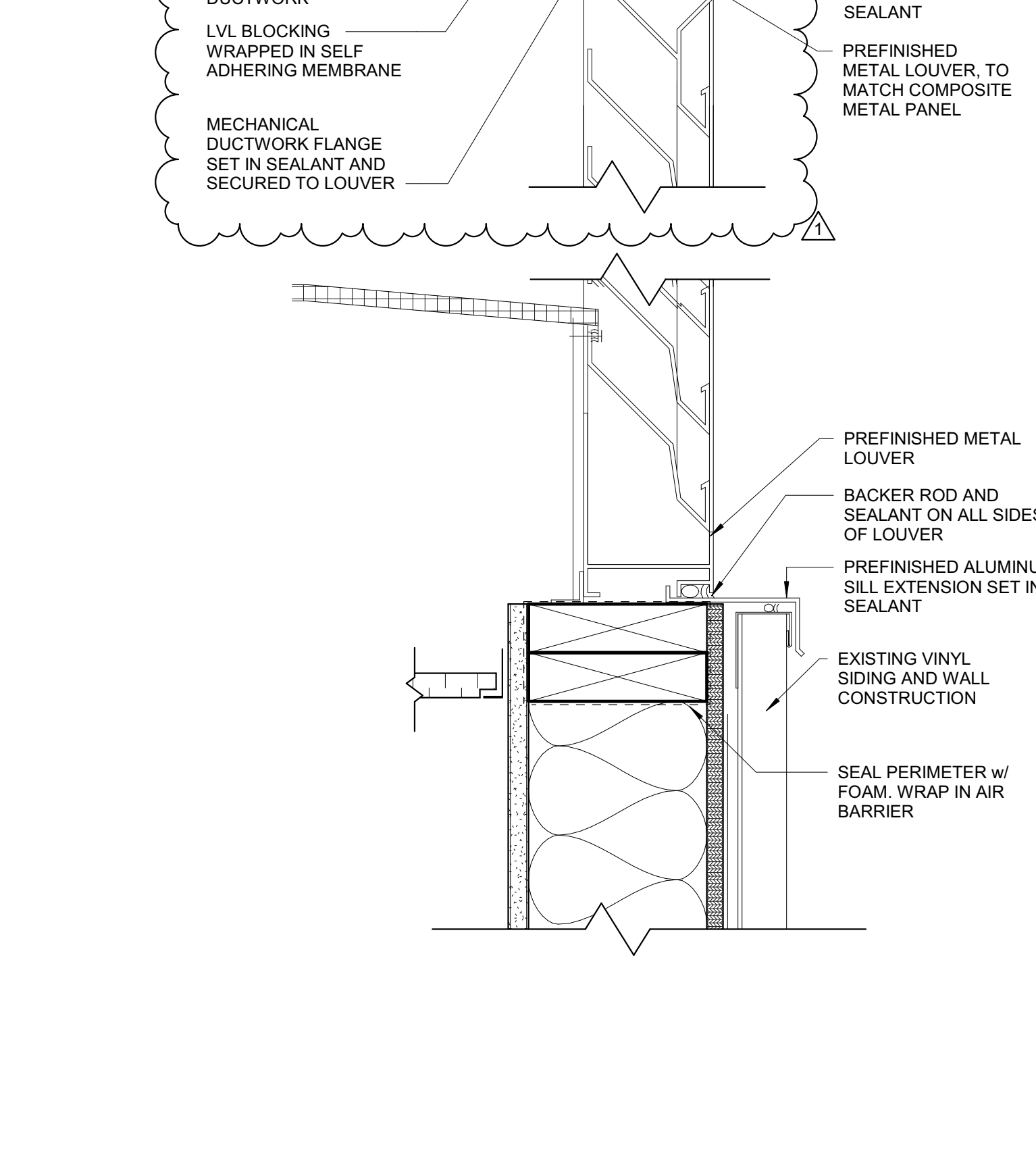
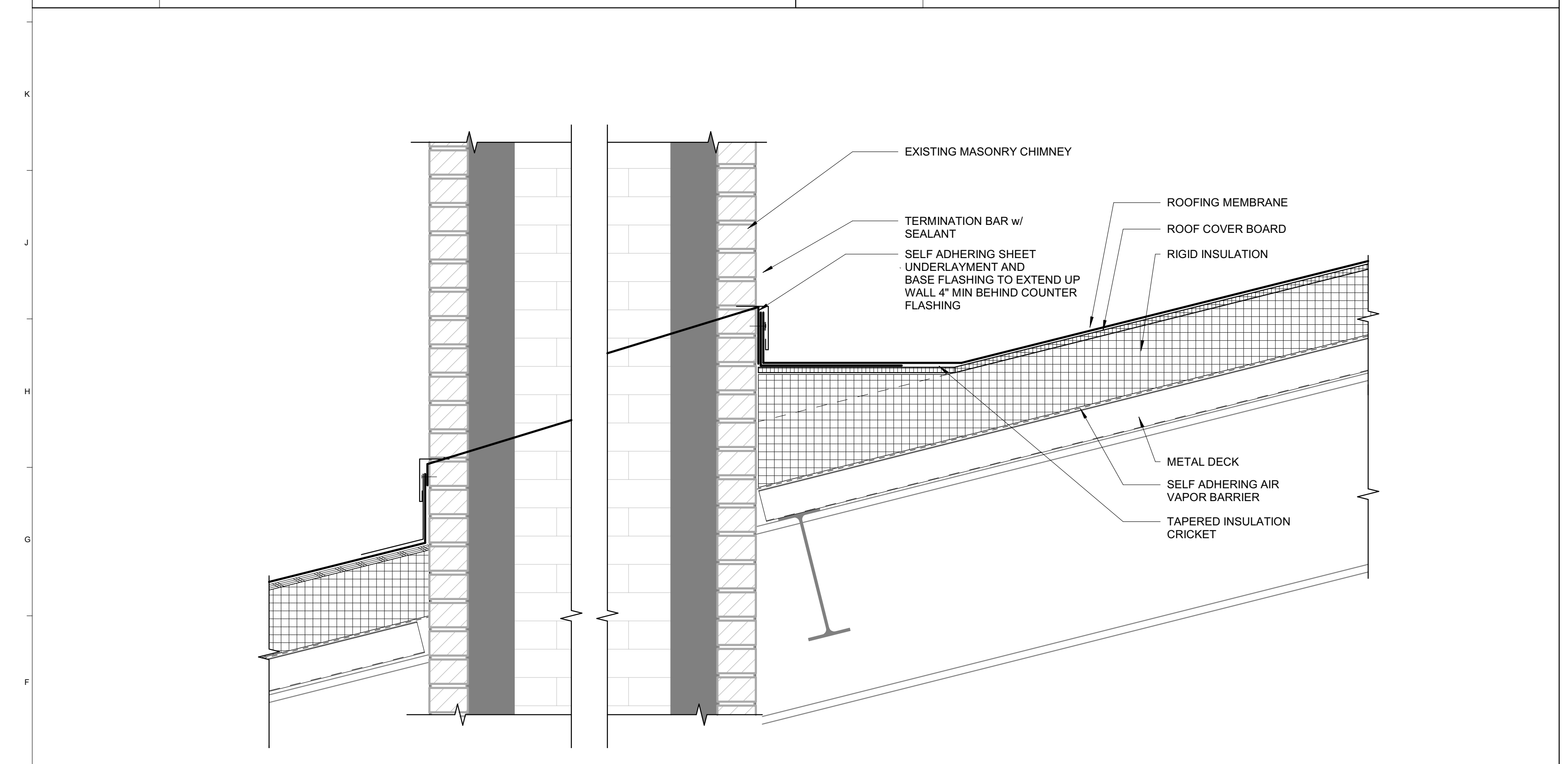

F1 CHIMNEY PENETRATION AND CRICKET DETAIL
 1 1/2" = 1'-0" AE103

F10 EAVE AND LOUVER DETAIL
 3" = 1'-0" AE102

F14 EAVE DETAIL
 3" = 1'-0" AE103

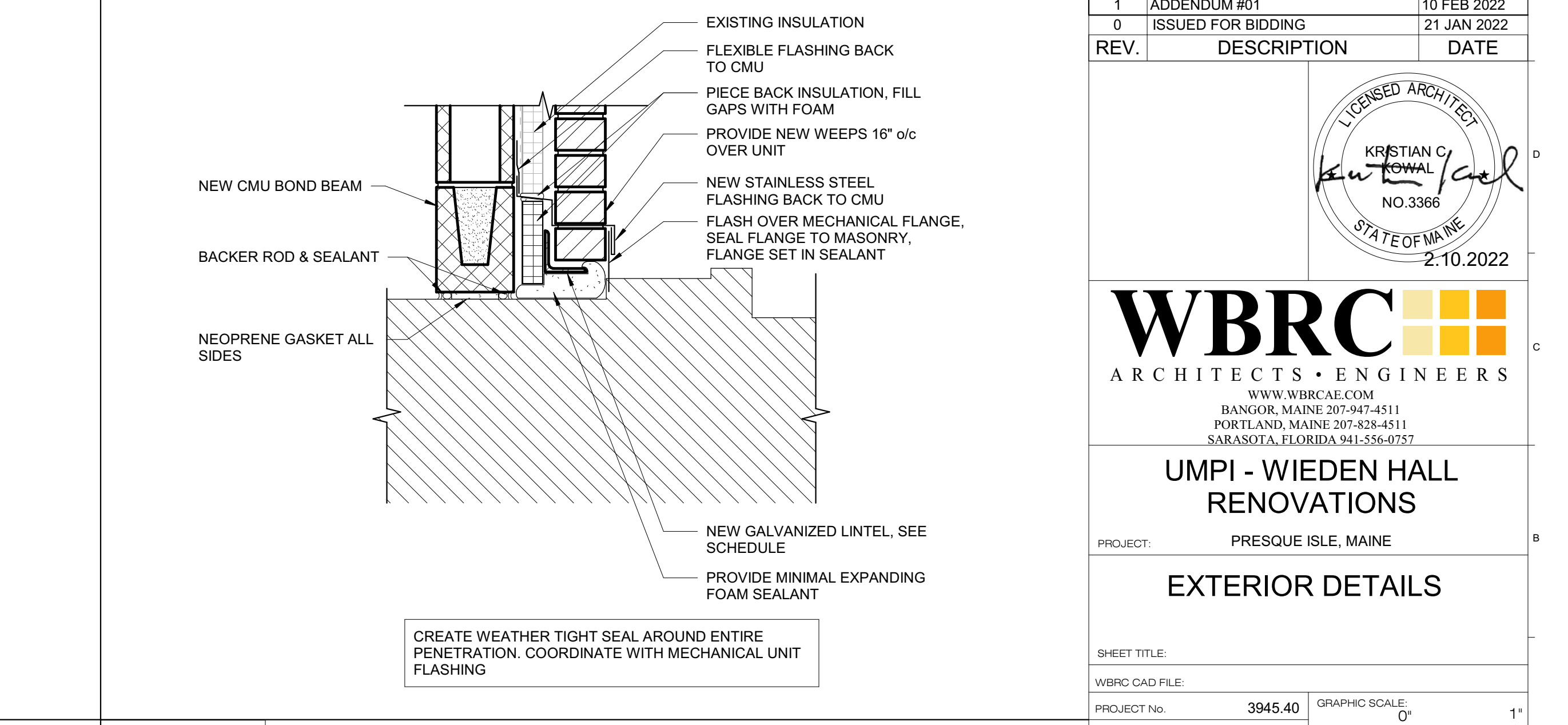
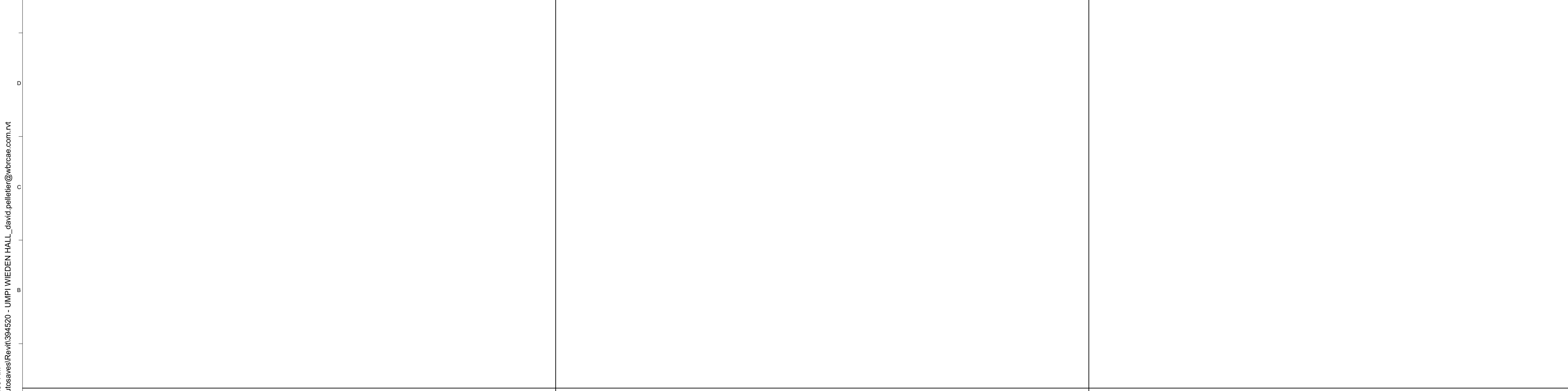

A14 WALL PENETRATION DETAIL
 1 1/2" = 1'-0" AE103

A14 WALL PENETRATION DETAIL
 1 1/2" = 1'-0" AE103

| 1 | ADDENDUM #01 | 10 FEB 2022 |
|------|--------------------|-------------|
| 0 | ISSUED FOR BIDDING | 21 JAN 2022 |
| REV. | DESCRIPTION | DATE |

WBRC
 ARCHITECTS • ENGINEERS
 WWW.WBRCAE.COM
 BANGOR, MAINE 207-641-4511
 PORTLAND, MAINE 207-828-4511
 SARASOTA, FLORIDA 941-556-8252
UMPI - WIEDEN HALL RENOVATIONS
 PROJECT: PRESQUE ISLE, MAINE
EXTERIOR DETAILS
 SHEET TITLE
 WBRC CAD FILE:
 PROJECT No: 3945.40 GRAPHIC SCALE: 0" = 1"
 SCALE: As indicated
 PROJECT MANAGER: Approver
 DRAWN BY: Author
 CHECKED BY: Checker
AE501

2/11/2022 8:29:30 AM
 U:\Autodesk AutoCAD\Revit\394520 - UMPI WIEDEN HALL_cad\vd.patel@wbrc.com

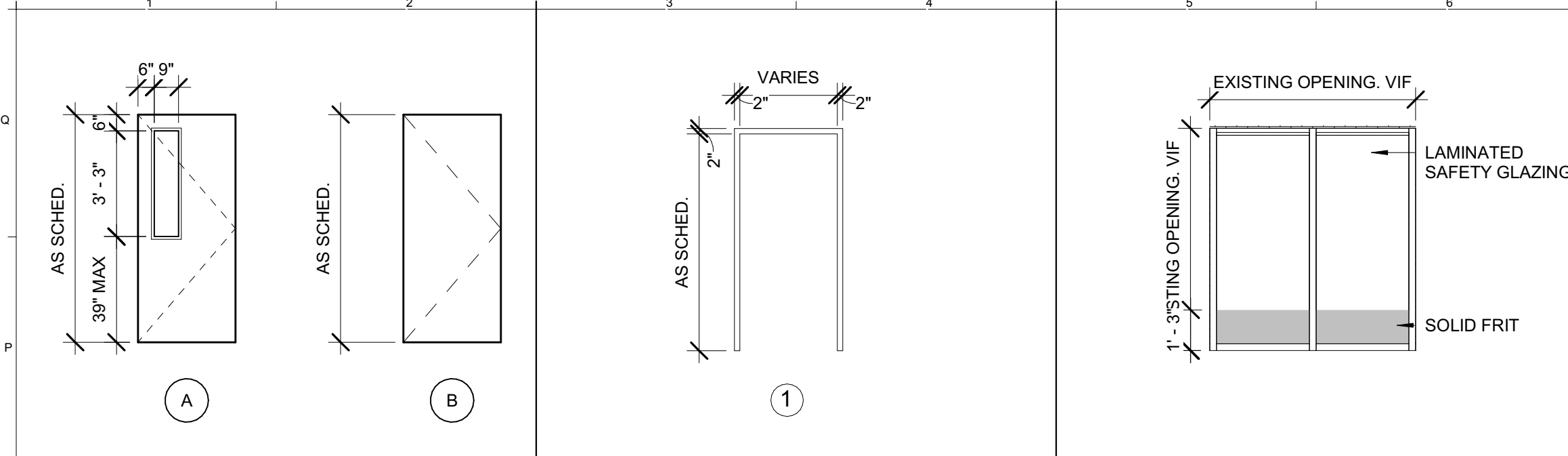

| DOOR SCHEDULE | | | | | | | | | | | | | |
|---------------|----------------|----------------|------|----------|----------------|-------|----------|--------|-----------|----------|----------|-------------|----------------------------|
| DOOR | | | | | | FRAME | | | | NOTES | | | |
| NUMBER | WIDTH | HEIGHT | TYPE | MATERIAL | FINISH | TYPE | MATERIAL | FINISH | HEAD | JAMB | GL | FIRE RATING | COMMENTS |
| 128 | MATCH EXISTING | MATCH EXISTING | C | | | 1 | HM | PT | M15/AE601 | G1/AE601 | TEMPERED | | MATCH EXISTING DOOR HEIGHT |
| 133A | 6' - 0" | MATCH EXISTING | A | WD | MATCH EXISTING | 1 | HM | PT | M15/AE601 | G1/AE601 | TEMPERED | | MATCH EXISTING DOOR HEIGHT |
| 133B | 6' - 0" | MATCH EXISTING | A | WD | MATCH EXISTING | 1 | HM | PT | M15/AE601 | G1/AE601 | TEMPERED | | MATCH EXISTING DOOR HEIGHT |
| 133C | 3' - 0" | MATCH EXISTING | A | WD | MATCH EXISTING | 1 | HM | PT | M15/AE601 | G1/AE601 | TEMPERED | | MATCH EXISTING DOOR HEIGHT |
| 133D | 3' - 0" | MATCH EXISTING | A | WD | MATCH EXISTING | 1 | HM | PT | M15/AE601 | G1/AE601 | TEMPERED | | ALTERNATE No. #1 |
| 133E | 3' - 0" | MATCH EXISTING | A | WD | MATCH EXISTING | 1 | HM | PT | M15/AE601 | G1/AE601 | TEMPERED | | ALTERNATE No. #1 |
| 133F | 6' - 0" | MATCH EXISTING | A | WD | MATCH EXISTING | 1 | HM | PT | M15/AE601 | G1/AE601 | TEMPERED | | ALTERNATE No. #1 |
| 133G | 6' - 0" | MATCH EXISTING | A | WD | MATCH EXISTING | 1 | HM | PT | M15/AE601 | G1/AE601 | TEMPERED | | ALTERNATE No. #1 |

| | | | | | |
|--------------|------------|--------------|------------------|--------------|--------|
| O1 | DOOR TYPES | O3 | DOOR FRAME TYPES | O5 | WINDOW |
| 1/4" = 1'-0" | | 1/4" = 1'-0" | | 1/4" = 1'-0" | AD101 |

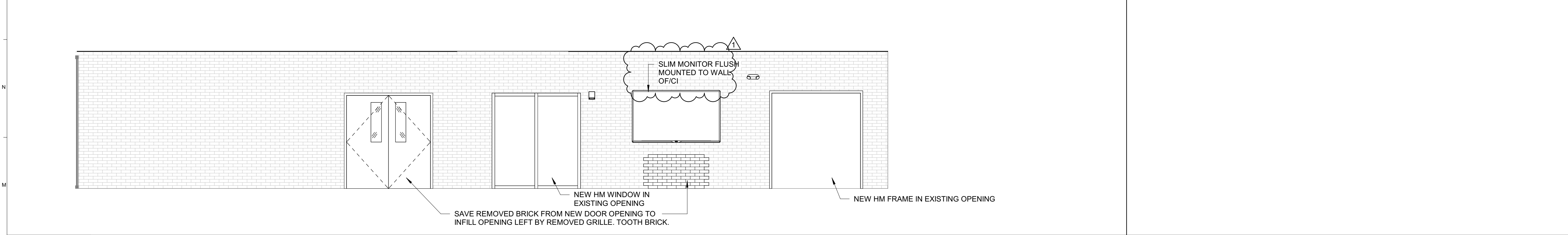

| | |
|--------------|------------|
| L1 | LOBBY WEST |
| 1/4" = 1'-0" | AD101 |

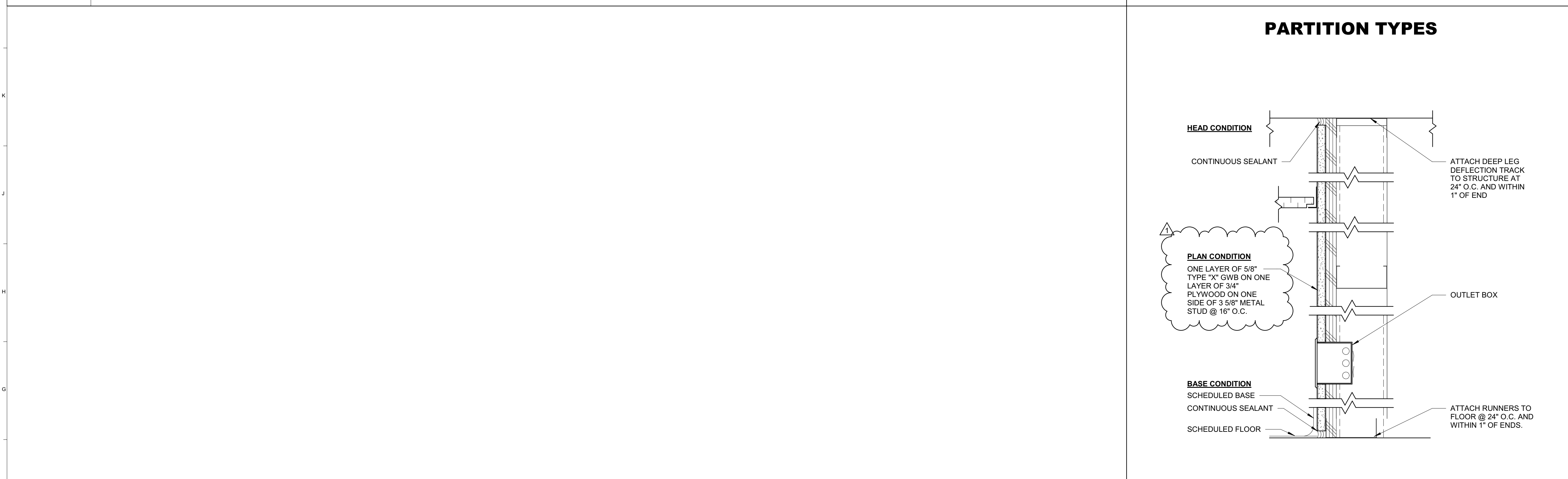

| | |
|------------|------------------------------|
| F11 | M5 - 3 5/8" METAL STUD CHASE |
| 3" = 1'-0" | |



| | |
|------------|-------------------------|
| A11 | M6 - 6" METAL STUD WALL |
| 3" = 1'-0" | |

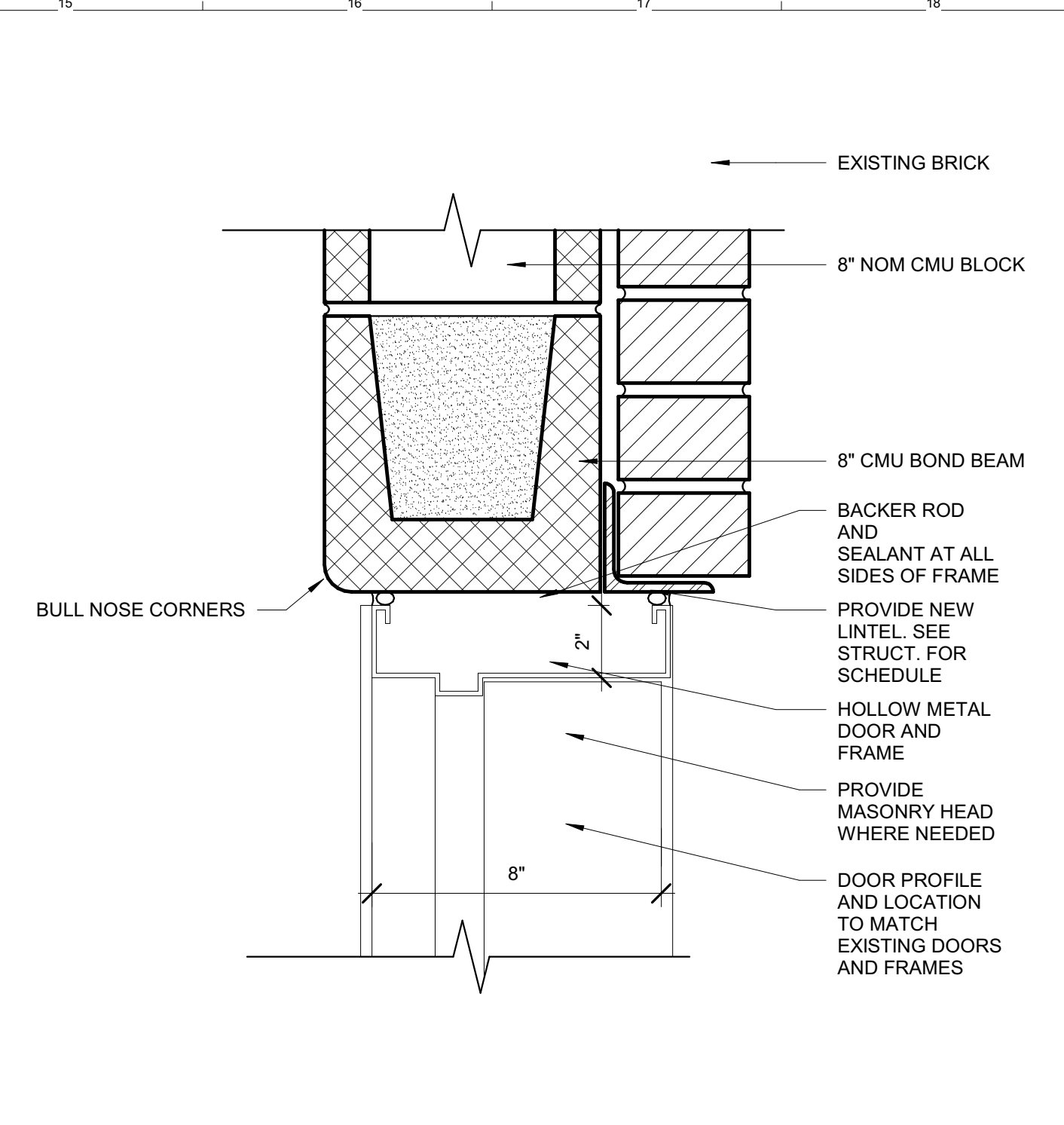

| | |
|------------|---------------------------|
| M15 | INTERIOR DOOR HEAD AT CMU |
| 3" = 1'-0" | |

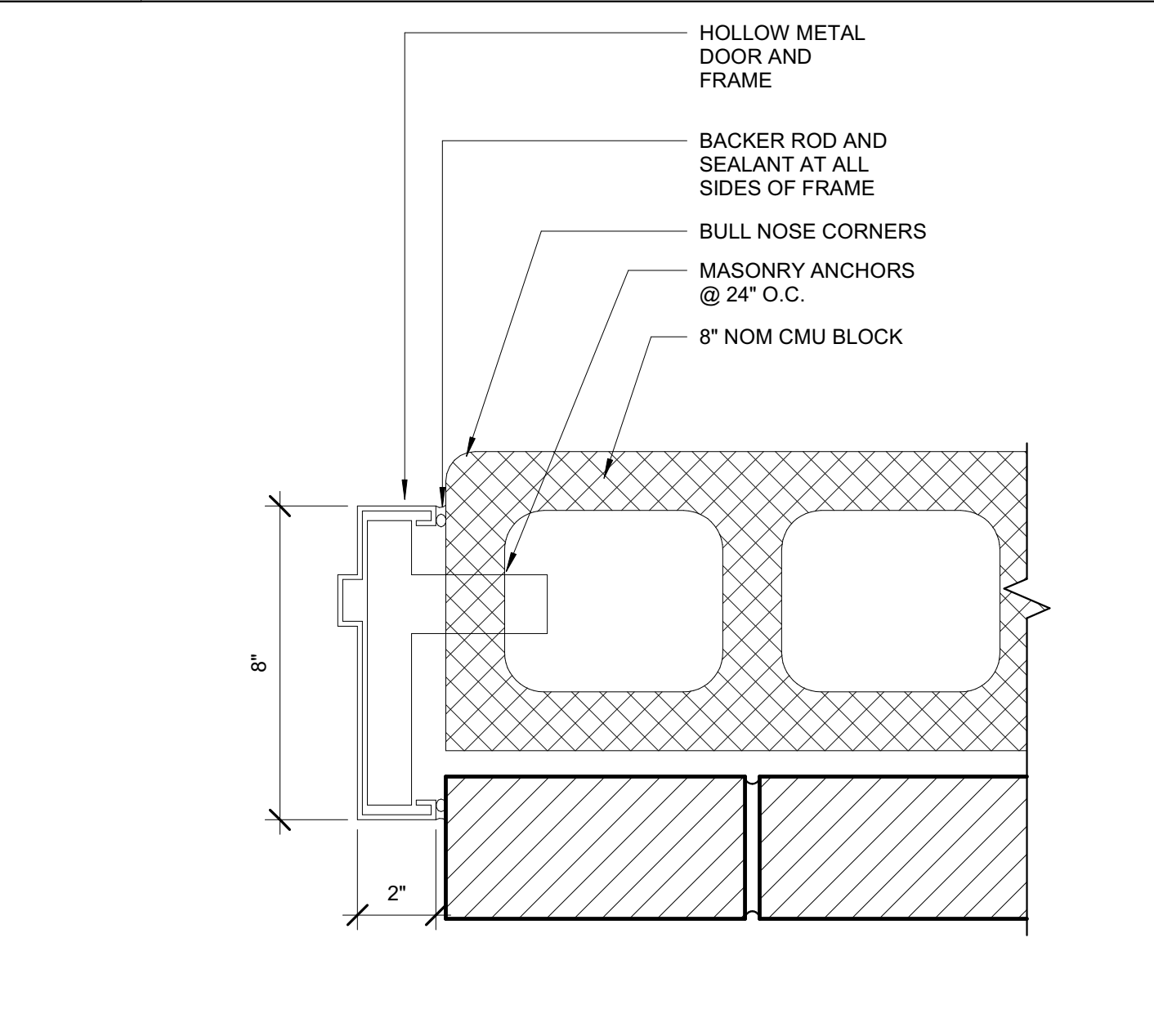

| | |
|------------|---------------------------|
| G15 | INTERIOR DOOR JAMB AT CMU |
| 3" = 1'-0" | |

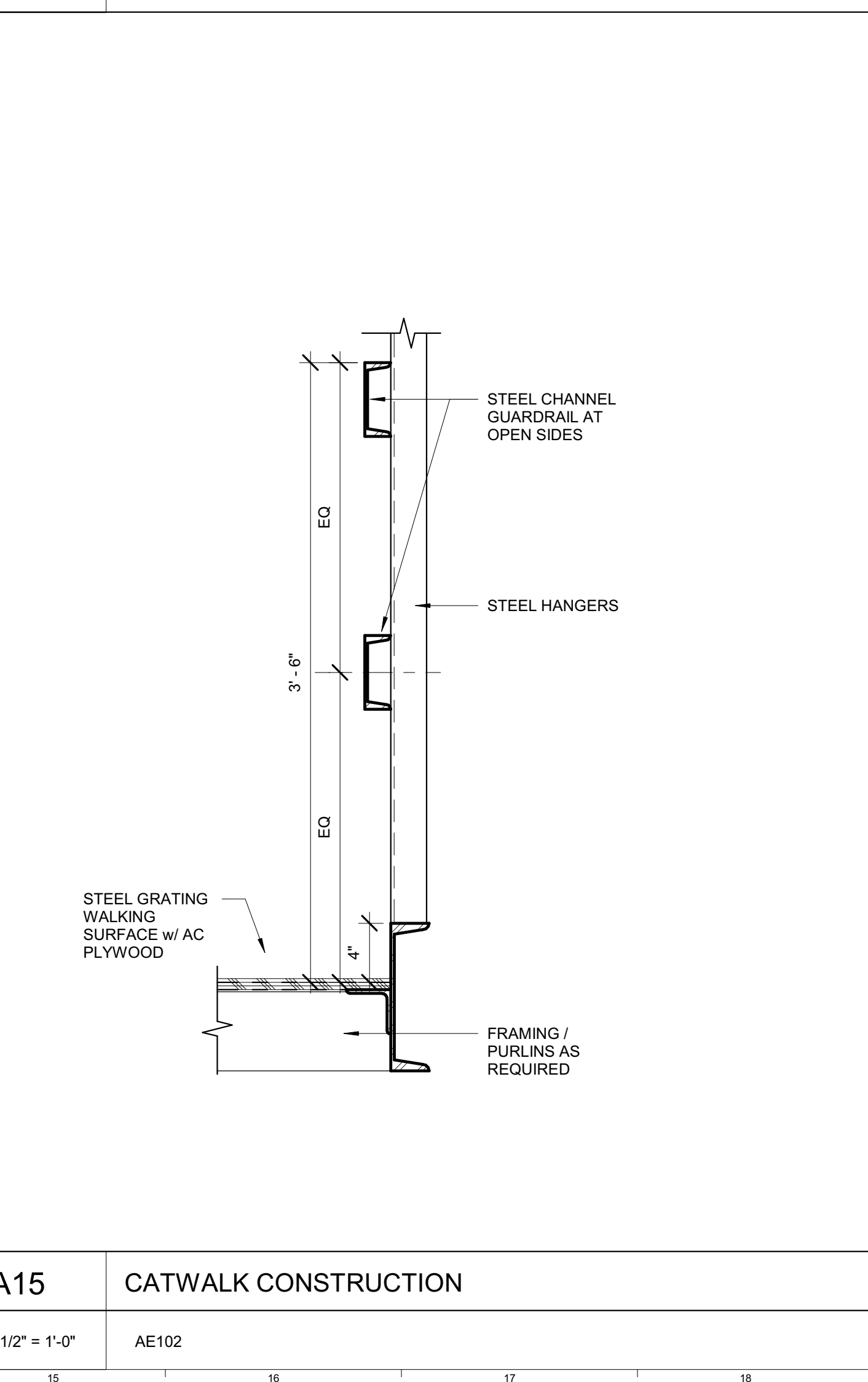

| | |
|----------------|----------------------|
| A15 | CATWALK CONSTRUCTION |
| 1 1/2" = 1'-0" | AE102 |

| | | |
|---|--------------------|-------------|
| 1 | ADDENDUM #01 | 10 FEB 2022 |
| 0 | ISSUED FOR BIDDING | 21 JAN 2022 |

| REV. | DESCRIPTION | DATE |
|------|-------------|------|
|------|-------------|------|

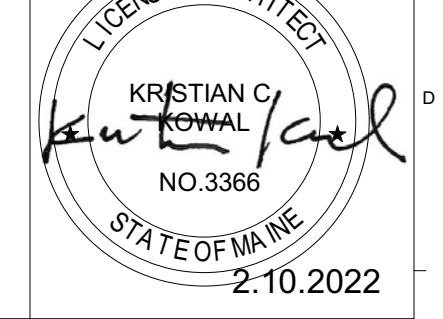

WBRC
ARCHITECTS • ENGINEERS
WWW.WBRCAE.COM
BANGOR, MAINE 207-943-4511
PORTLAND, MAINE 207-828-4511
SARASOTA, FLORIDA 941-556-8757

UMPI - WIEDEN HALL RENOVATIONS
PRESQUE ISLE, MAINE

DETAILS, SCHEDULE AND INTERIOR ELEVATIONS

| | |
|-----------------|--------------|
| SHEET TITLE | AE601 |
| WBRC CAD FILE | |
| PROJECT No. | 3945.40 |
| SCALE | As Indicated |
| PROJECT MANAGER | Approver |
| DRAWN BY | Author |
| CHECKED BY | Checker |

2/11/2022 8:29:38 AM U:\Autodesk\Autosaves\Revit\394540 - UMPI WIEDEN HALL_cad\vd.palatin@wbrc.com.rvt

| FINISH LEGEND | | | | | | | | | |
|---------------|-------|----------------------------|--|------------------|-------------------------------------|------------------------------|---------------------|--|--|
| SPEC | CODE | PRODUCT | MODEL | MANUFACTURER | COLOR | SIZE | FINISH | COMMENTS | |
| 093013 | CT-1 | CERAMIC TILE | KEYSTONES PENNY ROUNDS | DAL TILE | SUEDE GRAY D182 | 1"x1" MOUNTED ON 1'X2' SHEET | MATTE | LOCKER 136; LATICRETE SPECTRALOK PRO | |
| 095113 | APC-1 | ACOUSTIC PANEL CEILING | ULTIMA 1912 TEGULAR W/ PRELUDE GRID | ARMSTRONG | WHITE | 24"X24"; 15/16" GRID | | | |
| 095113 | APC-2 | ACOUSTIC PANEL CEILING | ULTIMA 1996 TEGULAR W/ PRELUDE GRID | ARMSTRONG | WHITE | 12"X48"; 15/16" GRID | | | |
| 096466 | WAF-1 | WOOD ATHLETIC FLOORING | REZILBASE | CONNOR | MAPLE | | | W/ TARKETT BLACK VENTED COVE | |
| 096513 | RST-1 | RESILIENT STAIR TREADS | VISUALLY IMPAIRED ANGLE FIT RUBBER TREAD W/ CONTRAST GRIT TAPE | TARKETT | SILVER GRAY 55/ BLACK RUBBER INSERT | | RICE PAPER | AT ALL STAIRS | |
| 096513 | RWB-1 | RESILIENT WALL BASE | MILLWORK REVEAL | TARKETT | SILVER GRAY 55 | 4.25" | | GENERAL WALL BASE | |
| 096513 | RWB-2 | RESILIENT WALL BASE | VENT COVE | TARKETT | BLACK | 4" | | GYM BASE | |
| 096519 | RTF-1 | RESILIENT TILE FLOORING | BBT STRIATIONS | ARMSTRONG | STEEL T3602 OR TWILIGHT T3603 | 12"X24" | | HERRINGBONE INSTALL ROOMS: 100,102,141,128,142,137,114,143, AND AS INDICATED ON PLAN | |
| 096813 | CPT-1 | CARPET TILE | FINE LINE | SHAW | GRAPHITE 13510 | 18"X36" | | OFFICES; MONOLITHIC INSTALL | |
| 098453 | SAW-1 | SOUND ACOUSTIC WALL PANELS | TECTUM | ARMSTRONG | PAIN TO MATCH PT-1 | | | | |
| 099123 | PT-1 | PAINT | GOH 32342742 | SCUFFMASTER | SP004 (GRAY) | | SMOOTH PEARL SATIN | GENERAL GYM WALL; RESTROOM WALLS | |
| 099123 | PT-2 | PAINT | GOH 32340845 | SCUFFMASTER | SP9623 (GOLD) | | SMOOTH PEARL SATIN | GYM CEILING AND COLUMNS | |
| 099123 | PT-3 | PAINT | PRO MAR 200 | SHERWIN WILLIAMS | REPOSE GRAY SW 7015 | | EG-SHELL/SEMI GLOSS | OFFICE AND CORRIDOR WALLS/SEMI GLOSS DOOR TRIM WITHIN SCOPE BOUNDARY | |
| 099123 | PT-4 | PAINT | PRO MAR 200 | SHERWIN WILLIAMS | DOVETAIL SW 7018 | | SEMI GLOSS | STAIR HANDRAIL AND TRIM | |
| 099123 | PT-5 | PAINT | PRO MAR 200 | SHERWIN WILLIAMS | MATCH PT-2 (GOLD) | | SEMI GLOSS | EXPOSED CEILING WITHIN SCOPE BOUNDARY | |

- FINISH NOTES:**
- REFER TO ARCHITECTURAL ABBREVIATIONS ON SHEET G102 FOR ALL ABBREVIATIONS SHOWN.
 - REFER TO THE REFLECTED CEILING PLAN ON SHEETS AE104 FOR MORE INFORMATION.
 - REFER TO SHEET AE501 FOR DOOR AND FRAME INFORMATION.
 - REFER TO SPECIFICATION FOR FLOORING TRANSITION INFORMATION. INSTALL NEW TRANSITION STRIPS WHERE NEW FLOORING MATERIAL ADJUTS DISSIMILAR FLOORING MATERIAL.
 - FLOORING CONTRACTOR TO VERIFY LOCATION AND STYLE OF FLOORING TRANSITION STRIPS BEFORE INSTALLATION.
 - FLOORING TRANSITIONS BETWEEN ROOMS TO OCCUR ON CENTER OF DOOR LEAF, UNO. COLOR TBD.
 - REFER TO FLOORING TRANSITION DETAILS ON AF101.
 - ALL GENERAL WALL PAINT TO BE PT-1 UNO. IN GYMNASIUM.
 - ALL GYM COLUMNS AND CEILING TO BE PT-2.
 - ALL OFFICE WALLS TO BE PT-3.
 - PAINT EXPOSED PIPE AND CONDUIT ADJACENT TO THE EXISTING METAL CEILING. PT-5. STOP AT THE BOTTOM FLANGE OF THE METAL BEAM.

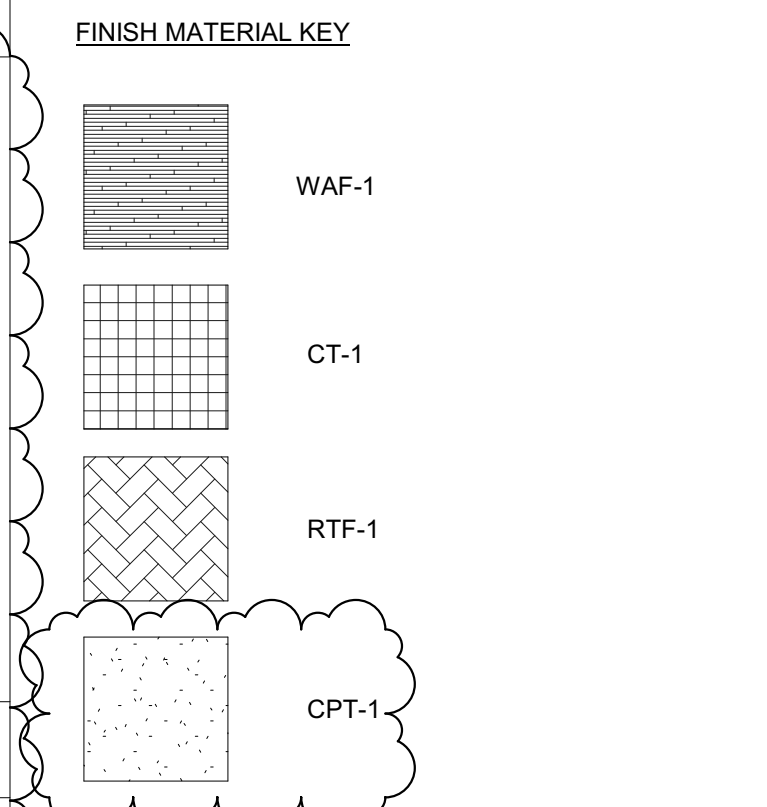
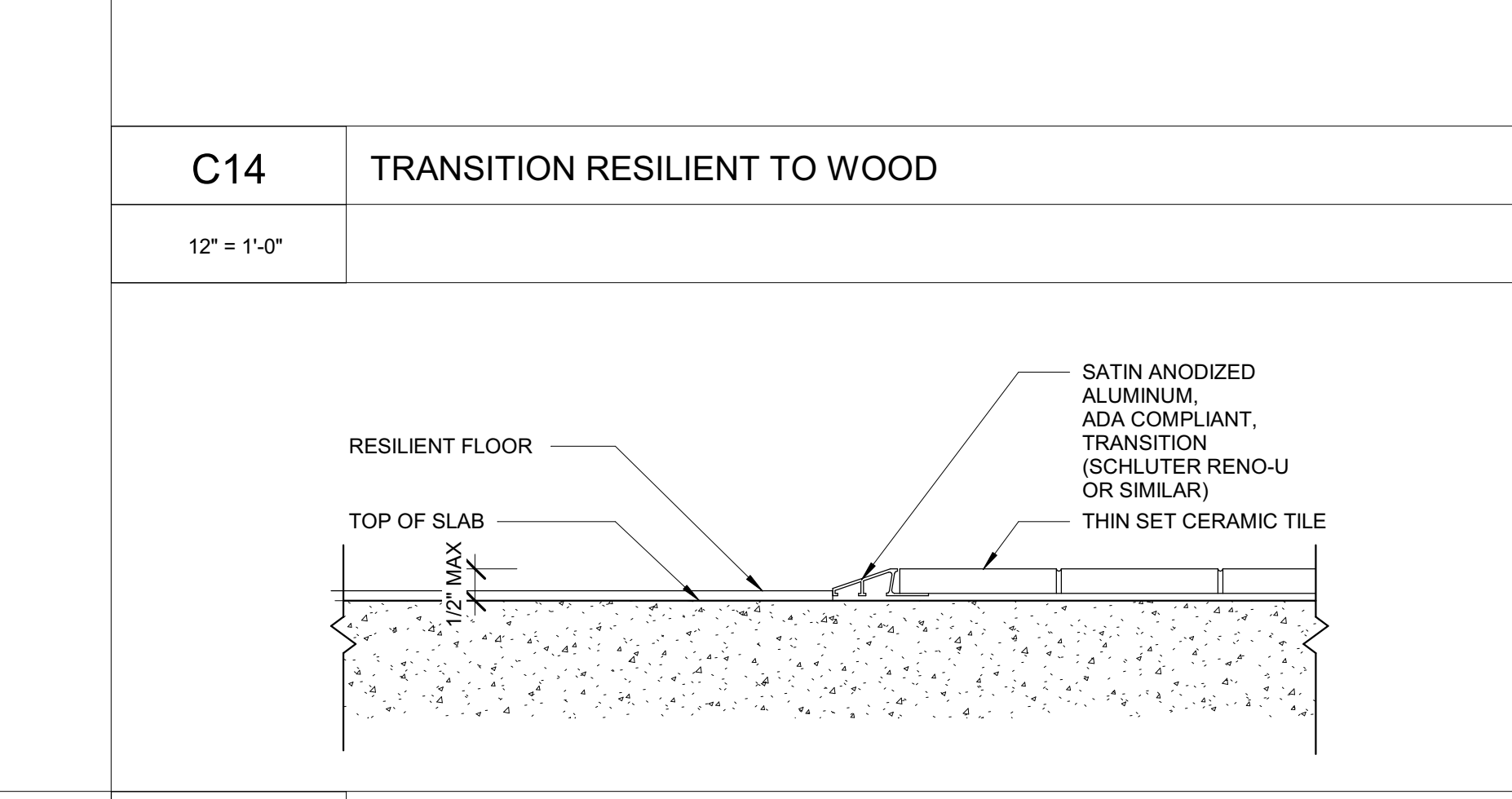
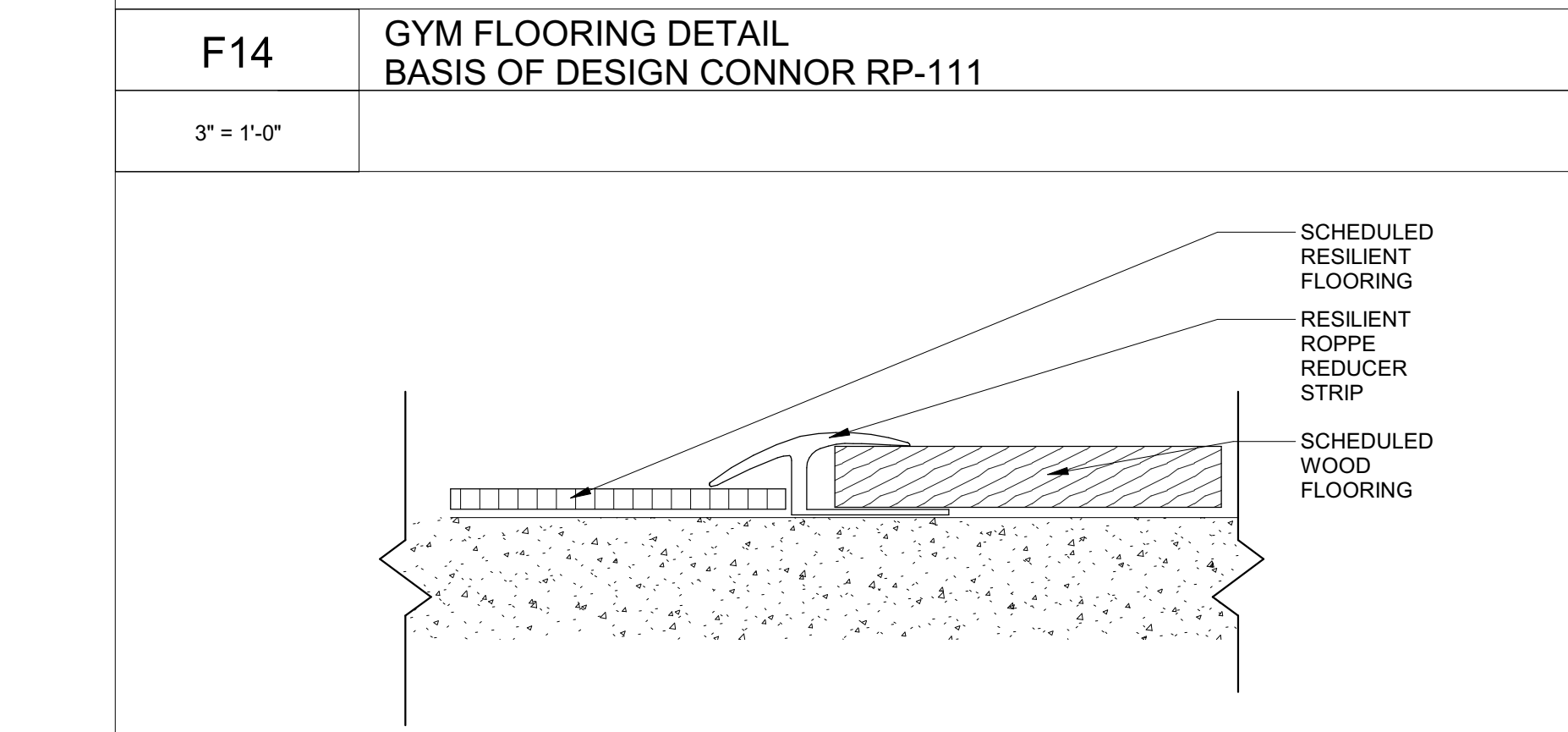
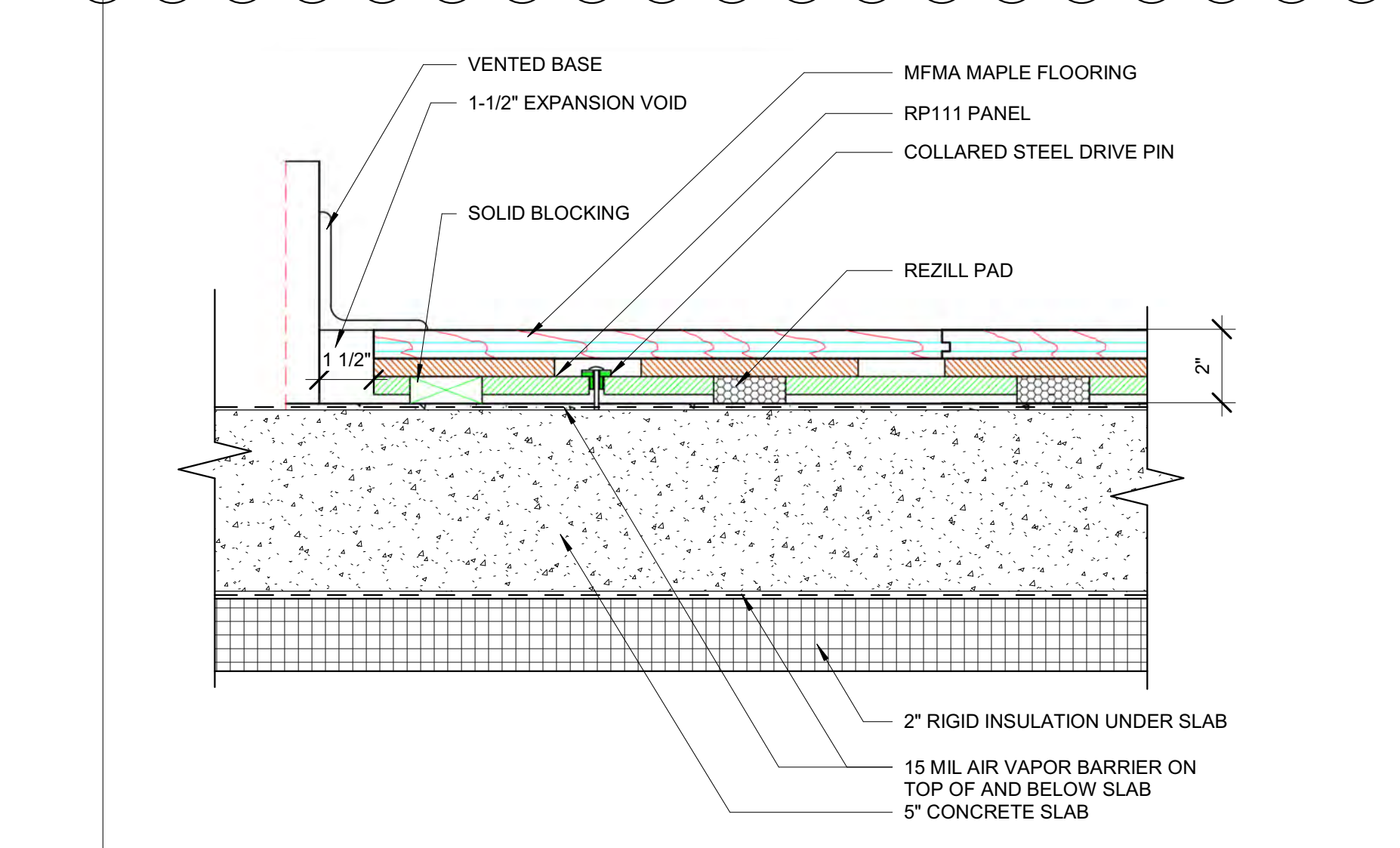
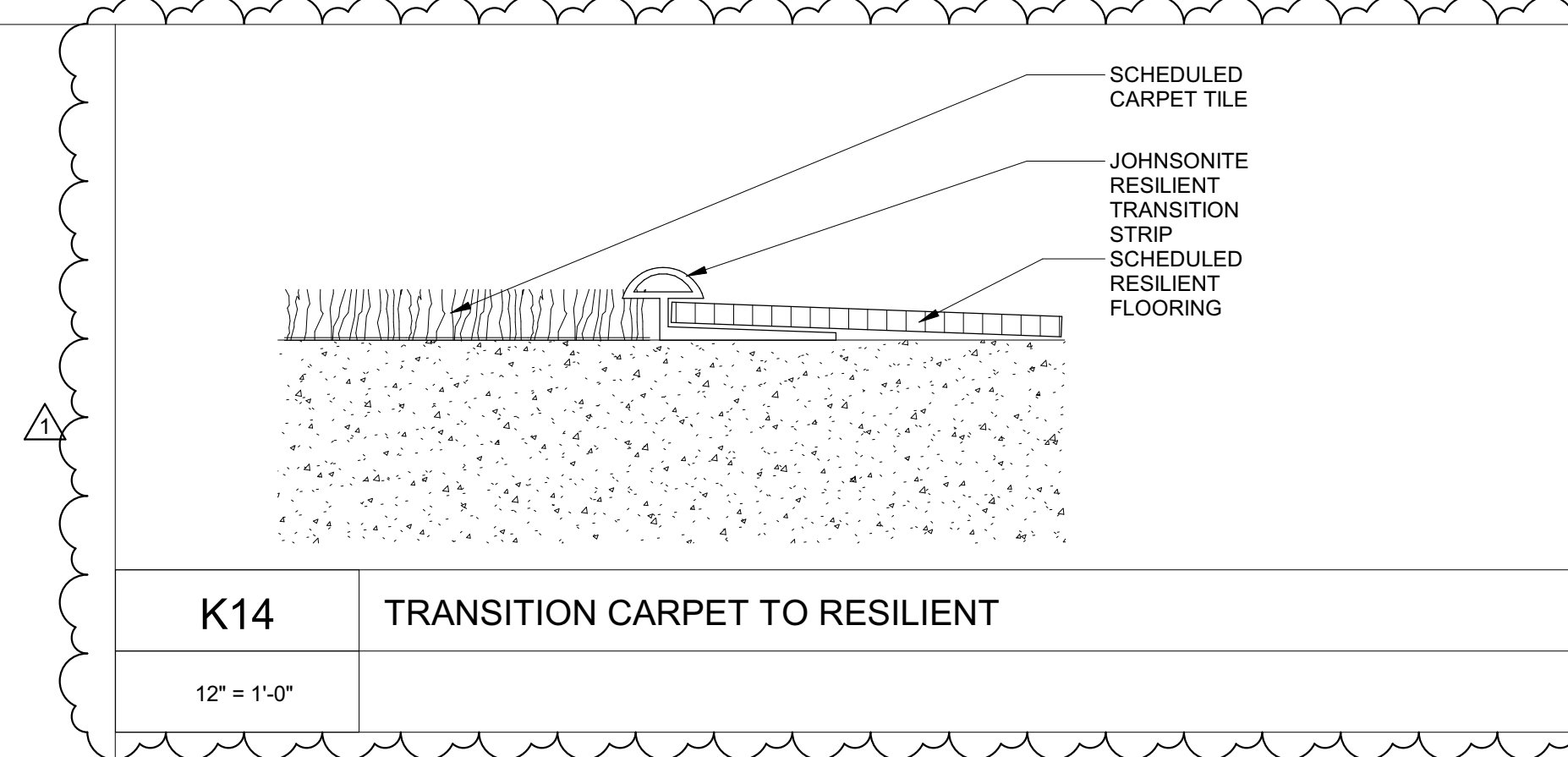
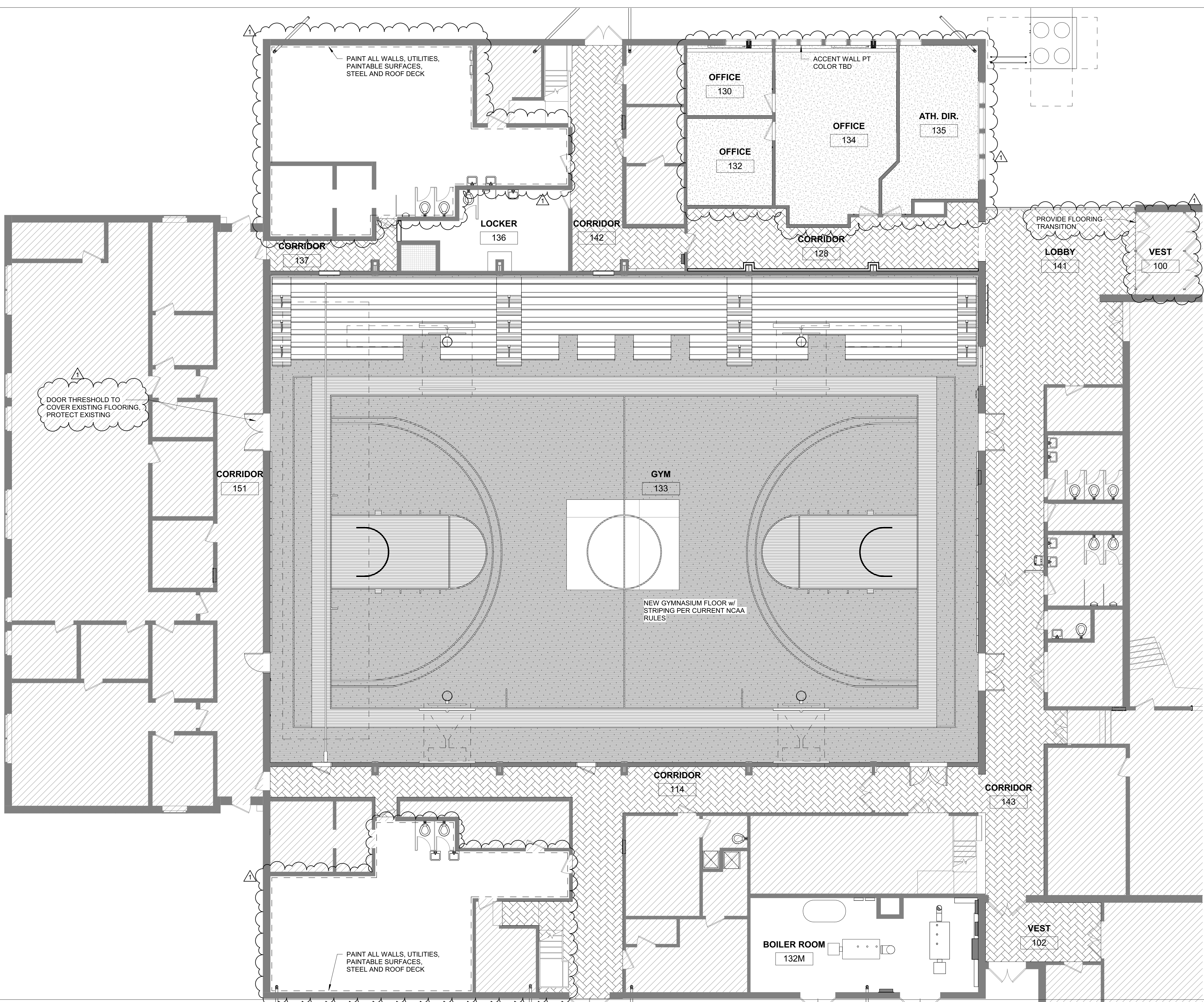

| 1 | ADDENDUM #01 | 10 FEB 2022 |
|------|--------------------|-------------|
| 0 | ISSUED FOR BIDDING | 21 JAN 2022 |
| REV. | DESCRIPTION | DATE |

PROJECT NORTH

WBRC
ARCHITECTS • ENGINEERS

UMPI - WIEDEN HALL RENOVATIONS

PROJECT: PRESQUE ISLE, MAINE

FINISH FLOOR PLAN

SHEET TITLE: WBRC CAD FILE: PROJECT No: 3945.40 GRAPHIC SCALE: 0' 1' SCALE: As Indicated PROJECT MANAGER: Approver SHEET No: AF101 DRAWN BY: Author CHECKED BY: Checker

2/11/2022 8:29:46 AM U:\Autodesk\Autodesk\Revit\394520 - UMPI WIEDEN HALL_cad\dwg\palletine@wbrc.com.rvt

2/9/2022 8:07:49 AM
U:\Autodesk\Autosaves\Revit\394540 - UMPI WIEDEN HALL-MECH-R2D_andrew.rvt\dwg\mech\394540-01.dwg

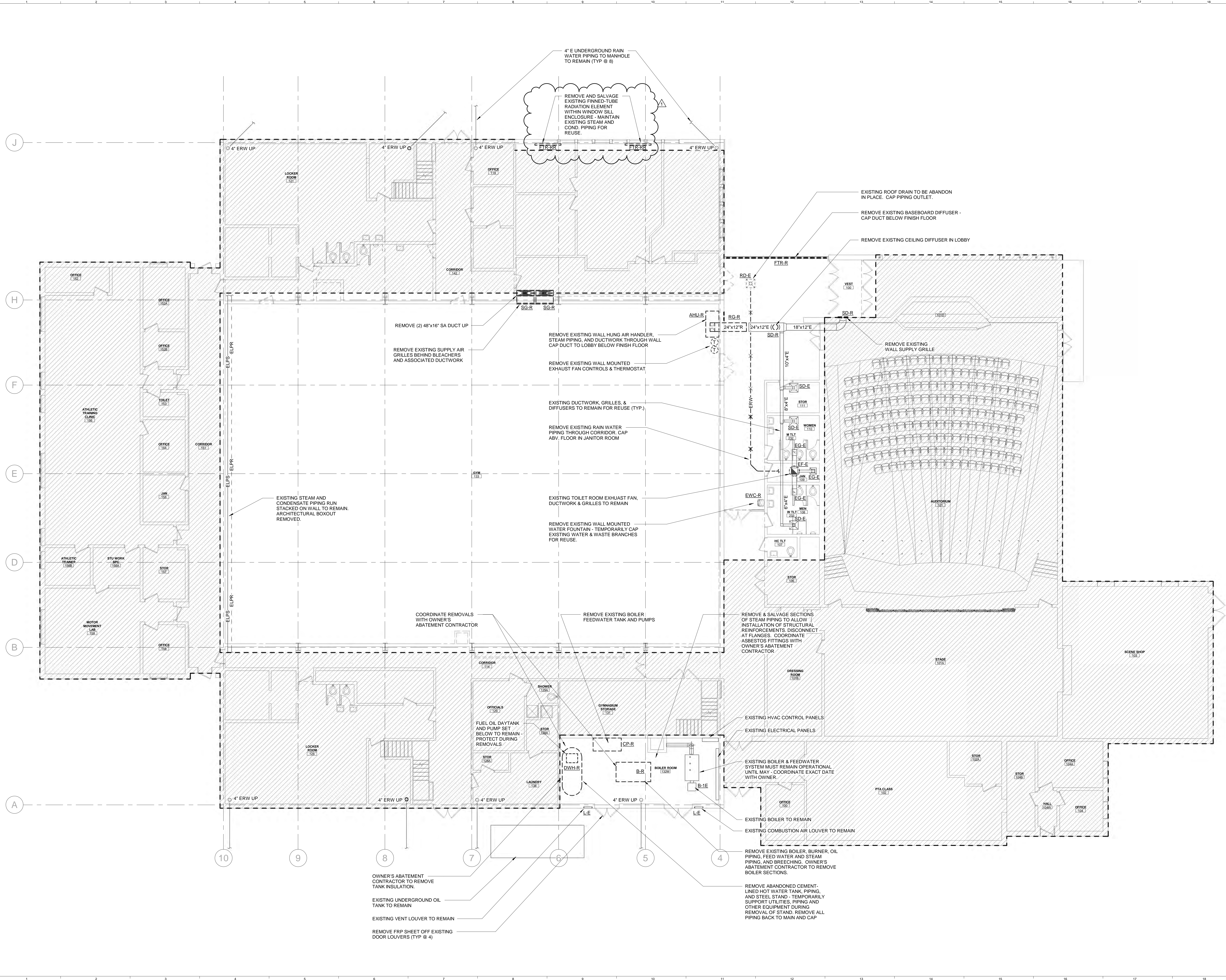

| 1 | ADDENDUM #01 | 10 FEB 2022 |
|------|--------------------|-------------|
| 0 | ISSUED FOR BIDDING | 21 JAN 2022 |
| REV. | DESCRIPTION | DATE |

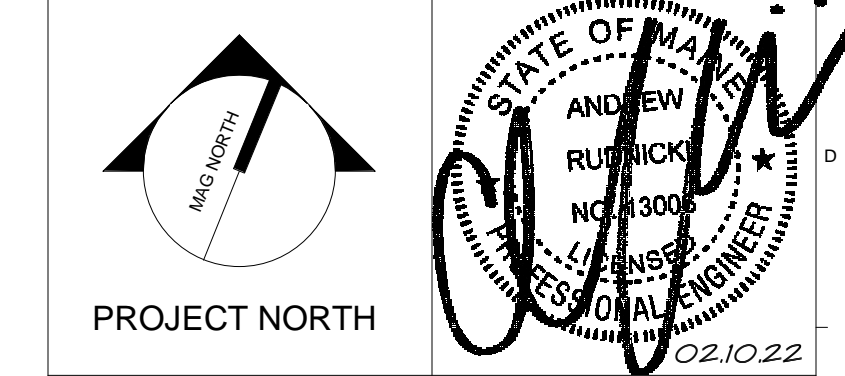

WBRC
ARCHITECTS • ENGINEERS
WWW.WBRC.AE.COM
BANGOR, MAINE 207-642-4511
PORTLAND, MAINE 207-828-4511
SARASOTA, FLORIDA 941-556-0757

UMPI - WIEDEN HALL RENOVATIONS
PROJECT: PRESQUE ISLE, MAINE

FIRST FLOOR MECHANICAL REMOVAL PLAN

| | |
|---|-------------------------|
| SHEET TITLE | |
| WBRC CAD FILE: 394540 - UMPI WIEDEN HALL-MECH-R2D.rvt | GRAPHIC SCALE: 1" = 10' |
| PROJECT No: 3945.40 | SHEET No: MD101 |
| SCALE: 1/8" = 1'-0" | DRAWN BY: SRJ |
| PROJECT MANAGER: KCK | CHECKED BY: AJR |

2/9/2022 8:07:41 AM
U:\Autodesk\Autodesk\Revit\394540 - UMPI WIEDEN HALL-MECH-R2D_andrew.rvt\dwg\394540.dwg

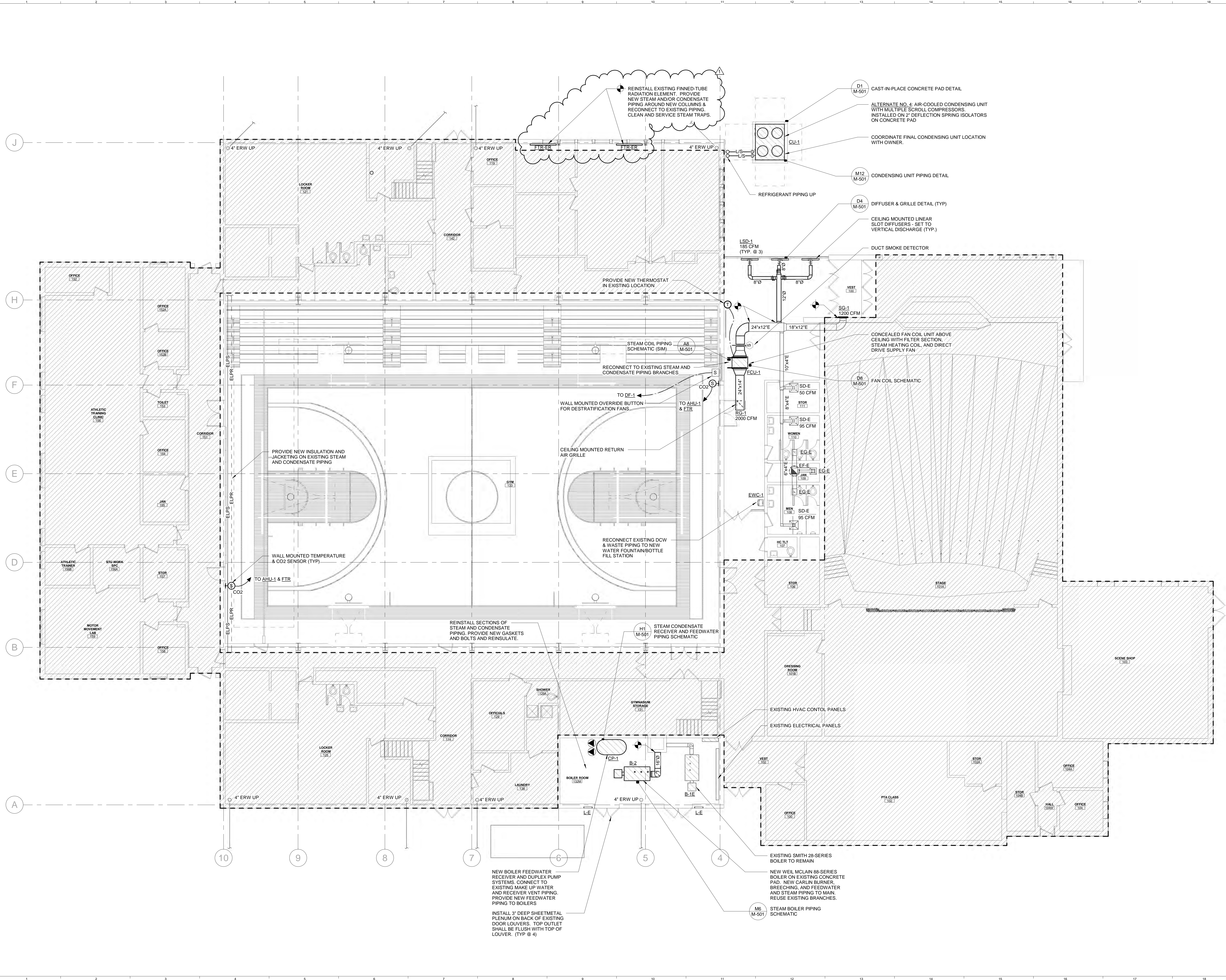

| 1 | ADDENDUM #01 | 10 FEB 2022 |
|------|--------------------|-------------|
| 0 | ISSUED FOR BIDDING | 21 JAN 2022 |
| REV. | DESCRIPTION | DATE |

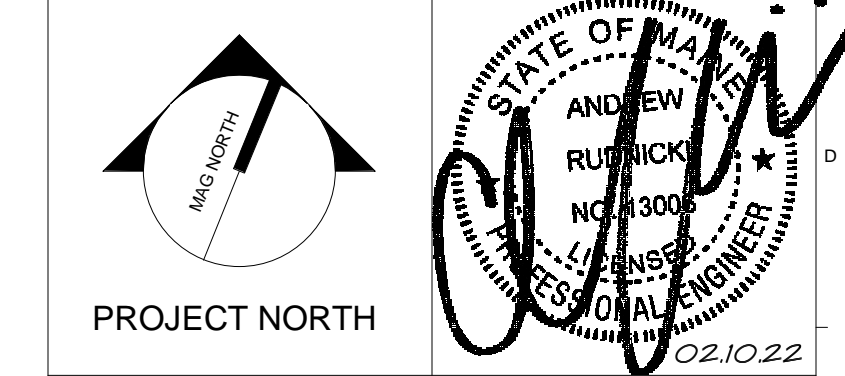

WBRC
ARCHITECTS • ENGINEERS
WWW.WBRCAE.COM
BANGOR, MAINE 207-642-4511
PORTLAND, MAINE 207-828-4511
SARASOTA, FLORIDA 941-556-8757

UMPI - WIEDEN HALL RENOVATIONS
PROJECT: PRESQUE ISLE, MAINE

FIRST FLOOR MECHANICAL PLAN

| | |
|---|---------------------------|
| SHEET TITLE | M-101 |
| WBRC CAD FILE: 394540 - UMPI WIEDEN HALL-MECH-R2D.rvt | GRAPHIC SCALE: 1" = 1'-0" |
| PROJECT No: 3945.40 | DRAWN BY: SRJ |
| SCALE: 1/8" = 1'-0" | CHECKED BY: AJR |
| PROJECT MANAGER: KCK | |

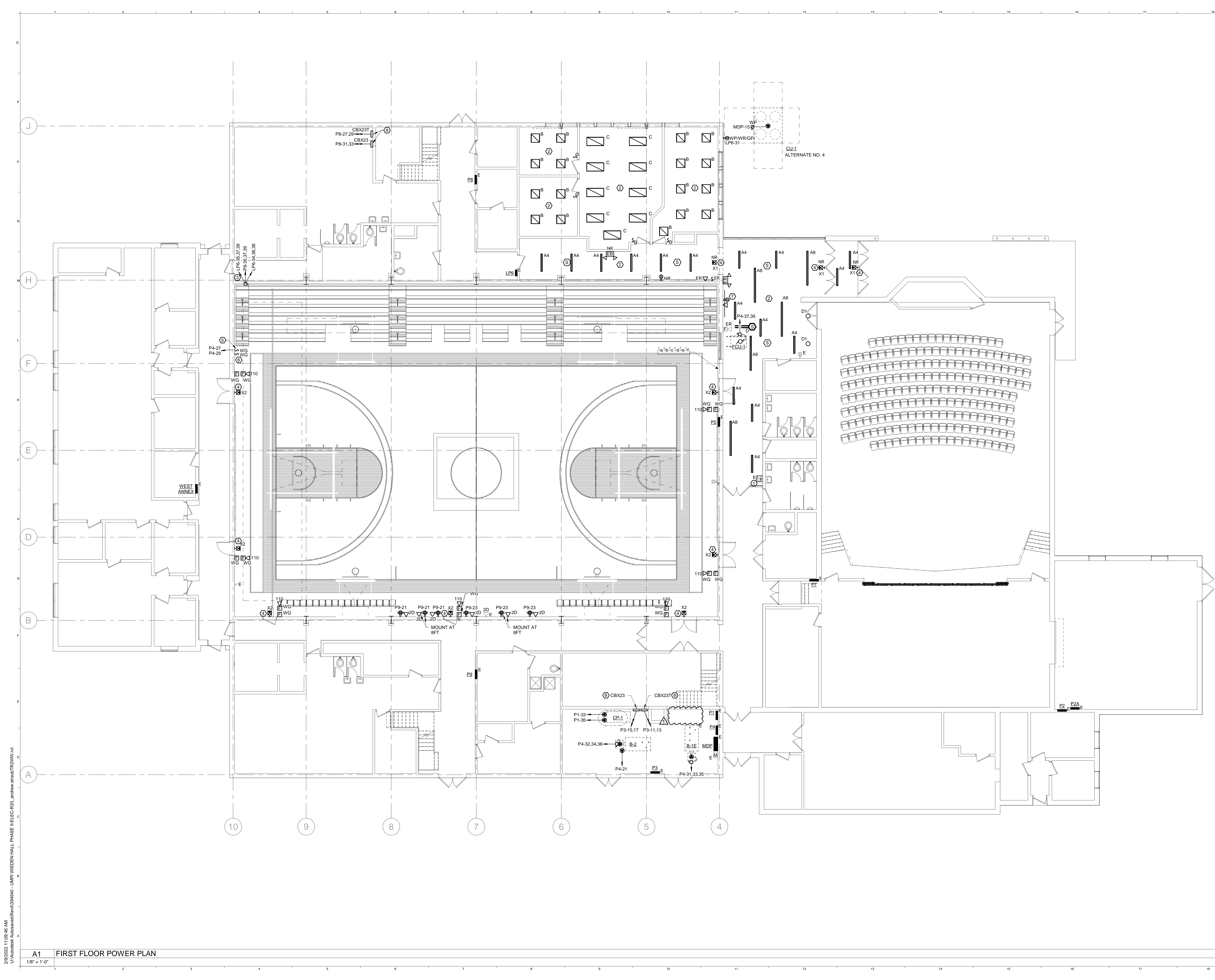

DRAWING NOTES:

- A. IN ANY AREAS REQUIRING STRUCTURAL ADDITIONS AND/OR REINFORCING FOR ROOF WORK, REMOVE OR TEMPORARILY SUPPORT ANY ELECTRICAL ITEM AS REQUIRED. REINSTALL AND RECONNECT IN SAME CONDITION AS FOUND UPON COMPLETION OF OTHER WORK IN THAT AREA.
- B. FOR DATA JACKS, PROVIDE JUNCTION BOX AND (2) PORT CAT 5 COVER PLATE WITH 3/4" CONDUIT AND PULLSTRINGS FROM IT CLOSET TO DEVICE LOCATION.

TECHNICAL NOTES:

- ① CONNECT NEW ADA WATER FOUNTAIN TO EXISTING CIRCUIT.
- ② CEILING TO BE REPLACED. EC TO TEMPORARILY SUPPORT, EXTEND AND REINSTALL ALL EXISTING ELECTRICAL DEVICES IN NEW CEILING AS REQUIRED UNO. REFER TO ARCHITECTURAL PLANS. CONNECT NEW LIGHT FIXTURES TO EXISTING LIGHTING CIRCUITS AND CONTROLS, UNO.
- ③ INTEGRAL BLEACHER POWER SUPPLY. PROVIDE MANUAL LOCKING NON FUSED DISCONNECT AND SEATING POWER AS INDICATED. INSTALL CONTROL BOX 18" ABOVE FLOOR. SEE MANUFACTURER'S COMPLETE SPECIFICATIONS FOR INSTALLATION.
- ④ CONNECT NEW EXIT SIGNAGE TO EXISTING EXIT SIGNAGE CIRCUIT.
- ⑤ BASIS OF DESIGN: PROVIDE POWR-TOUCH 2.5 GYM CONTROL CENTER. SEE MANUFACTURER'S COMPLETE SPECIFICATIONS FOR INSTALLATION. COORDINATE FINAL LOCATION WITH OWNER PRIOR TO INSTALLATION.
- ⑥ TOUCHPAD CONTROLLER. PROVIDE (2) 12V POWER AND (2) COMMUNICATIONS WIRES FROM GYM CONTROL PANEL TO TOUCHPAD. SEE MANUFACTURER'S COMPLETE SPECIFICATIONS FOR INSTALLATION AND MATERIALS REQUIRED. COORDINATE FINAL LOCATION WITH OWNER PRIOR TO INSTALLATION.
- ⑦ POWER AND DATA FOR TV MONITOR. MOUNT AT 48" AFF. CONNECT OUTLET TO NEAREST LIGHTLY LOADED EXISTING CIRCUIT.
- ⑧ PROVIDE COMPLETE INSTALLATION OF SNOW MELT LOW VOLTAGE CONTROL UNITS. BASIS OF DESIGN IS HEATIZON SYSTEMS CBX SERIES. REFER TO SPEC SECTION 10800 AND MANUFACTURER'S INSTRUCTIONS FOR COMPLETE SYSTEM ELECTRICAL PRODUCTS AND REQUIREMENTS. COORDINATE FINAL LOCATIONS OF CONTROL UNITS WITH OWNER PRIOR TO INSTALLATION.

| 1 | ADDENDUM #01 | 10 FEB 2022 |
|------|----------------|-------------|
| 0 | ISSUED FOR BID | 21 JAN 2022 |
| REV. | DESCRIPTION | DATE |



WBRC
ARCHITECTS • ENGINEERS

WWW.WBRCAE.COM
BANGOR, MAINE 207-463-4511
PORTLAND, MAINE 207-838-4511
SARASOTA, FLORIDA 941-556-0252

**UMPI WIEDEN HALL
ELECTRICAL SERVICE**

PROJECT: PRESQUE ISLE, MAINE

FIRST FLOOR ELECTRICAL PLAN

| | | |
|------------------|--------------|---------------------------|
| SHEET TITLE | | E-101 |
| WBRC CAD FILE | | |
| PROJECT No. | 3945.40 | GRAPHIC SCALE: 1" = 1'-0" |
| SCALE: | 1/8" = 1'-0" | |
| PROJECT MANAGER: | KCX | |
| DRAWN BY: | DVS | |
| CHECKED BY: | ACS | |

2/9/2022 11:05:46 AM U:\AutoDesk\Autosaves\Revit\394540 - UMPI WIEDEN HALL PHASE I\ELEC\R20_andrew_straub\TR20\WV.MXD

A1 FIRST FLOOR POWER PLAN
1/8" = 1'-0"

GENERAL NOTE:
1. ALL SURFACE MOUNTED EXPOSED BACK BOXES TO BE CAST BOXES.

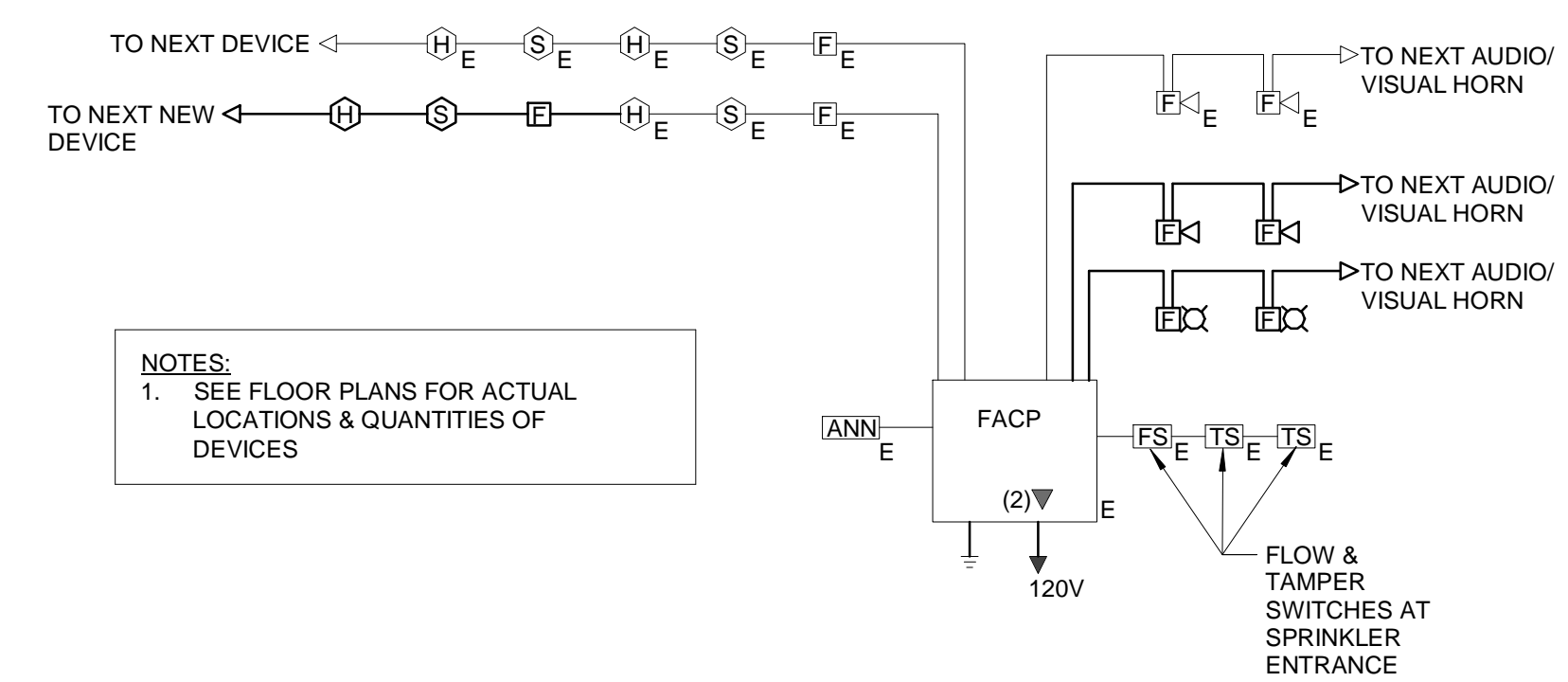

NOTES:
1. SEE FLOOR PLANS FOR ACTUAL LOCATIONS & QUANTITIES OF DEVICES

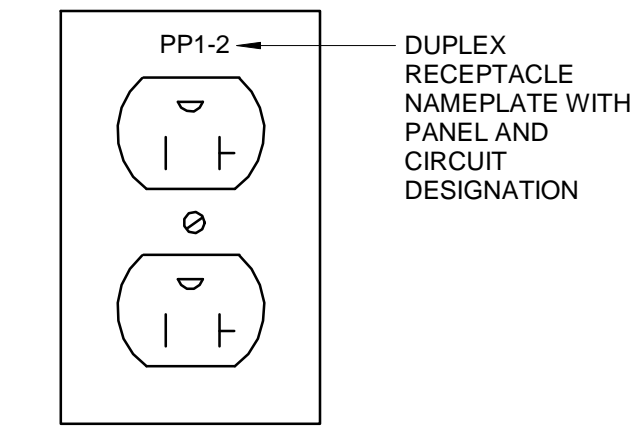

1 TYP. ELECTRICAL LABELING

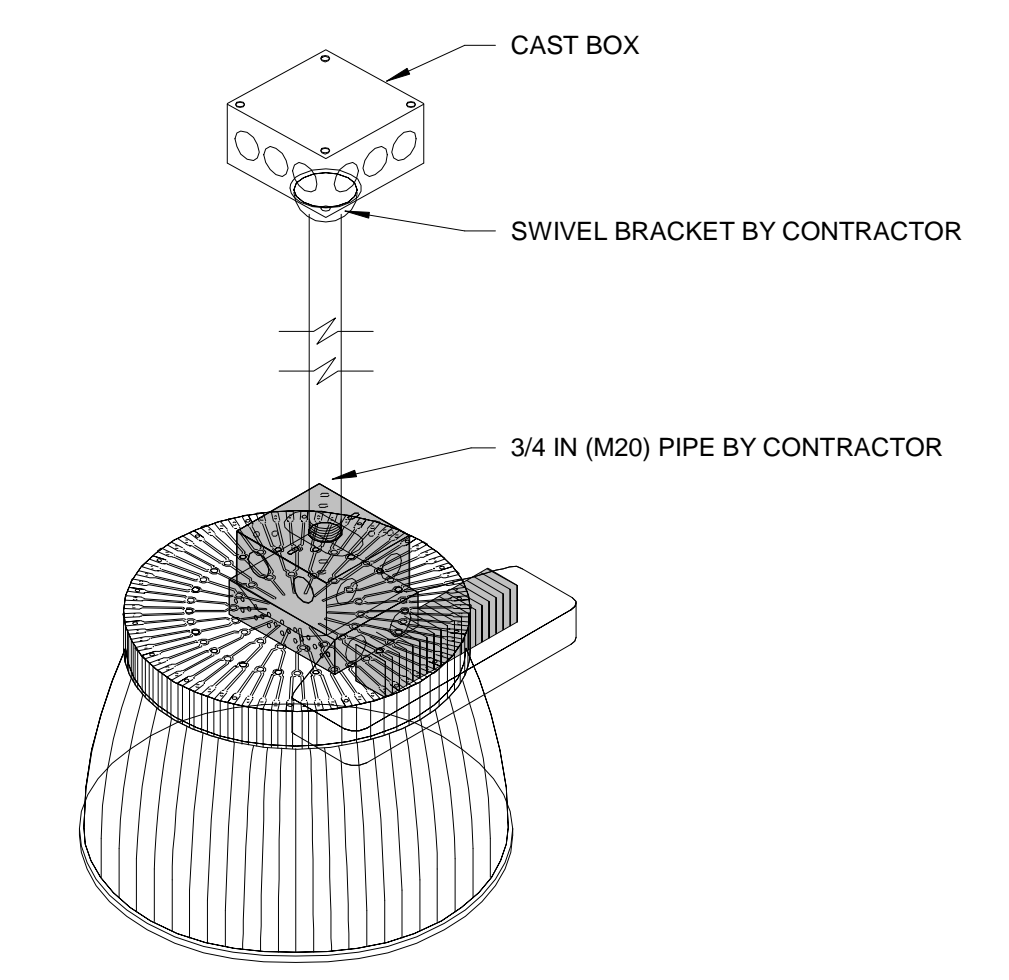

3 TYPE A MOUNTING DETAIL

2 EXISTING FIRE ALARM SYSTEM RISER DIAGRAM
1/4" = 1'-0"

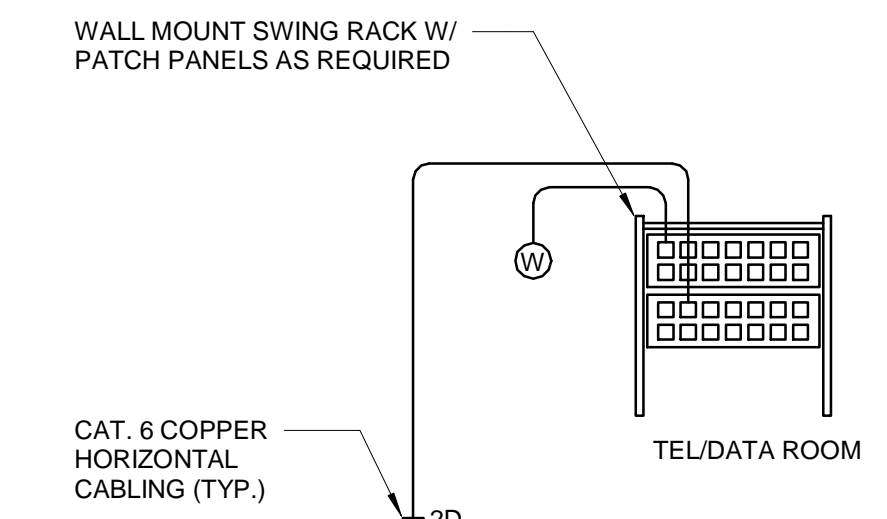

NOTE:
ALL NEW HORIZONTAL CABLING SHALL BE RUN TO RACK IN TEL/DATA ROOM

4 EXISTING TELECOMMUNICATIONS RISER DIAGRAM
1/4" = 1'-0"

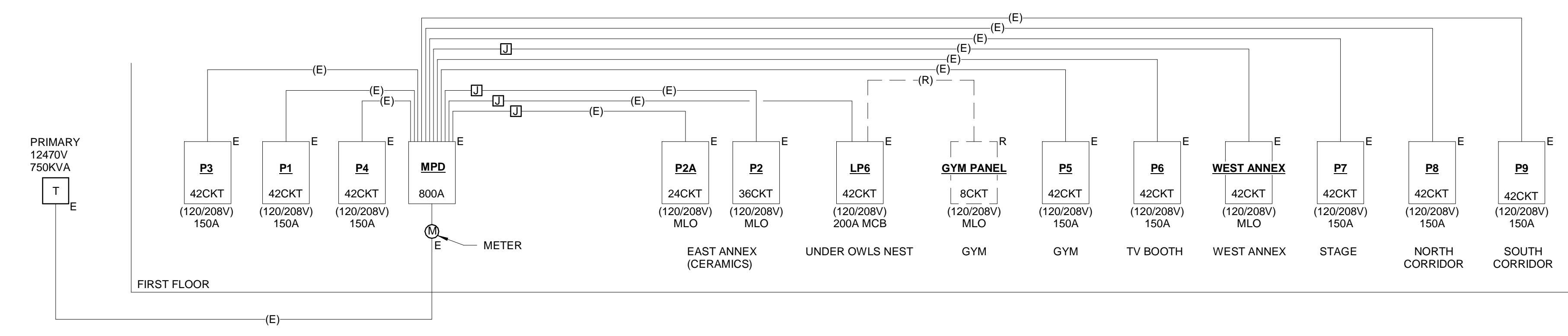
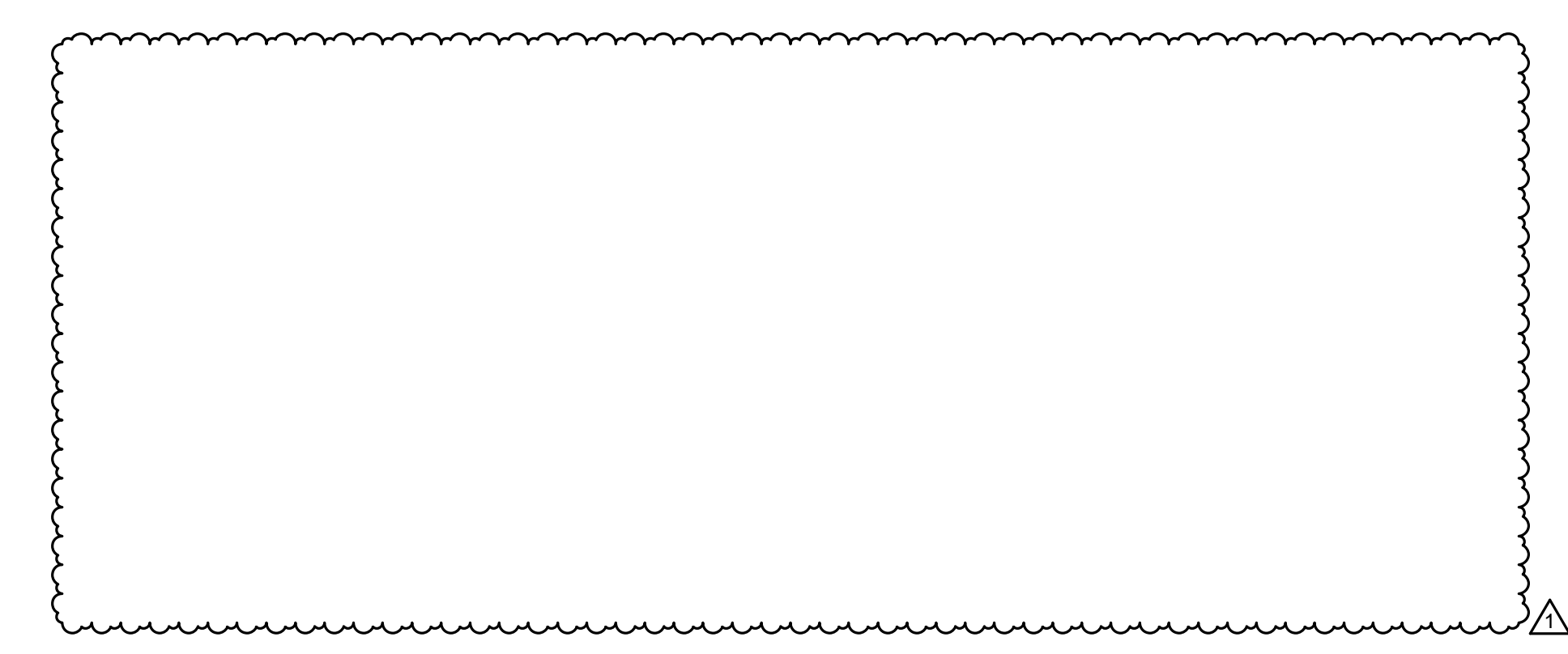

| | | |
|---|----------------|-------------|
| 1 | ADDENDUM #01 | 10 FEB 2022 |
| 0 | ISSUED FOR BID | 21 JAN 2022 |

| REV. | DESCRIPTION | DATE |
|------|-------------|------|
|------|-------------|------|

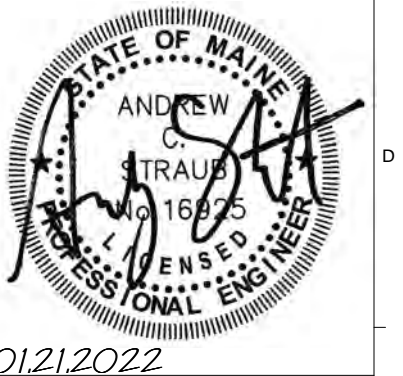

WBRC
ARCHITECTS • ENGINEERS
WWW.WBRCAE.COM
BANGOR, MAINE 207-943-4511
PORTLAND, MAINE 207-838-4511
SARASOTA, FLORIDA 941-556-0252

**UMPI WIEDEN HALL
ELECTRICAL SERVICE**
PROJECT: PRESQUE ISLE, MAINE

ELECTRICAL DETAILS

| | |
|----------------------|-------------------|
| SHEET TITLE | |
| WBRC CAD FILE: | GRAPHIC SCALE: 0' |
| PROJECT No: 3945.40 | 1" |
| SCALE: AS INDICATED | |
| PROJECT MANAGER: KCK | SHEET No: E-501 |
| DRAWN BY: DVS | |
| CHECKED BY: ACS | |

2/9/2022 11:05:47 AM U:\Autodesk\Autodesk\Revit\394540 - UMPI WIEDEN HALL PHASE I\ELEC-R20_andrew_straub\TR20\WV.MXD

A1 ELECTRICAL 1-LINE DIAGRAM
NTS

GENERAL NOTES:

A. ALL CIRCUITS SHOWN ARE EXISTING UNLESS OTHERWISE NOTED AS NEW.
B. PROVIDE UPDATED PANEL SCHEDULES FOR ALL PANELS WITH NEW WORK.

PANEL P5 VOLTAGE: 120/208V PHASES: 3 WIRE: 4 TYPE: EXISTING LOCATION: SEE FLOOR PLANS MOUNTING: RECESSED

PANEL P2A VOLTAGE: 120/208V PHASES: 3 WIRE: 4 TYPE: EXISTING LOCATION: SEE FLOOR PLANS MOUNTING: SURFACE

MDP VOLTAGE: 120/208V PHASES: 3 WIRE: 4 TYPE: MDP LOCATION: SEE FLOOR PLAN MOUNTING: SURFACE

PANEL P6 VOLTAGE: 120/208V PHASES: 3 WIRE: 4 TYPE: EXISTING LOCATION: SEE FLOOR PLANS MOUNTING: SURFACE

PANEL P3 VOLTAGE: 120/208V PHASES: 3 WIRE: 4 TYPE: EXISTING LOCATION: SEE FLOOR PLANS MOUNTING: SURFACE

PANEL P1 VOLTAGE: 120/208V PHASES: 3 WIRE: 4 TYPE: EXISTING LOCATION: SEE FLOOR PLANS MOUNTING: SURFACE

PANEL P7 VOLTAGE: 120/208V PHASES: 3 WIRE: 4 TYPE: EXISTING LOCATION: SEE FLOOR PLANS MOUNTING: SURFACE

PANEL P4 VOLTAGE: 120/208V PHASES: 3 WIRE: 4 TYPE: EXISTING LOCATION: SEE FLOOR PLANS MOUNTING: SURFACE

PANEL P2 VOLTAGE: 120/208V PHASES: 3 WIRE: 4 TYPE: EXISTING LOCATION: SEE FLOOR PLANS MOUNTING: RECESSED

PANELBOARD NOTES:

- 1. EXISTING EXISTING BREAKER AND LOAD TO BE MAINTAINED.
2. EXISTING CIRCUIT BREAKER WITH LOAD RENAMED TO MATCH RENOVATION.
3. EXISTING SPARE CIRCUIT BREAKER WITH NEW LOAD APPLIED.
4. EXISTING POLE SPACE WITH NEW CIRCUIT BREAKER AND LOAD APPLIED.

Revision table with columns: REV., DESCRIPTION, DATE

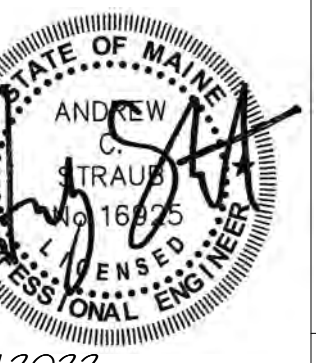

WBRC ARCHITECTS • ENGINEERS

UMPI WIEDEN HALL ELECTRICAL SERVICE

PROJECT: PRESQUE ISLE, MAINE

PANELBOARD SCHEDULES

Project information table including SHEET TITLE, WBRC CAD FILE, PROJECT No., SCALE, PROJECT MANAGER, DRAWN BY, CHECKED BY, and SHEET No. E-601